

# EGOAT Project

**Sponsors:** Orlando Utility Commissions (OUC), and Duke Energy



## **Group 23:**

Tyler Bradley | EE - Track: Comprehensive  
Daniel Corbellini | EE - Track: Power and Renewable Resources  
Nathaniel McKain | CpE - Track: Comprehensive  
Joseph Morelli | EE - Track: Comprehensive

December 4th, 2019

## Table Of Contents

1. Executive Summary
2. Project Description
  - 2.1. Project Motivation and Goals
    - 2.1.1. Project Needs Analysis
  - 2.2. Objectives
  - 2.3. Existing Similar Projects and Products
    - 2.3.1. MowBot
    - 2.3.2. Ryobi Model RY 40109
    - 2.3.3. Robomow
    - 2.3.4. Tertill
  - 2.4. Requirement Specifications
    - 2.4.1. Mechanical Consideration
    - 2.4.2. Competition Scoring
  - 2.5. Initial Block Diagrams
  - 2.6. House of Quality Analysis
3. Research Related to Project Description
  - 3.1. Relevant Technologies
    - 3.1.1. Batteries
    - 3.1.2. Sensors
      - 3.1.2.1. Battery Temperature sensor
    - 3.1.3. Autonomy
    - 3.1.4. Power Sub-System
    - 3.1.5. PCB Layout
    - 3.1.6. Communications Hardware System
    - 3.1.7. Communication Mediums
    - 3.1.8. GPS Tracking
    - 3.1.9. Fencing
    - 3.1.10. Close Collision Sensor
    - 3.1.11. Relays
    - 3.1.12. Motor Control
    - 3.1.13. Blade Motor Controller
    - 3.1.14. Mechanical Overview
      - 3.1.14.1. Torque Vs. Speed
      - 3.1.14.2. Gear Ratio/Gear Systems
      - 3.1.14.3. Electric Motor vs Gas
      - 3.1.14.4. Tire and Tread
      - 3.1.14.5. Motor Trimmer
  - 3.2. Part selection
    - 3.2.1. Switching Regulator
    - 3.2.2. Battery
      - 3.2.2.1. Nickel Cadmium
      - 3.2.2.2. Lithium-Ion
      - 3.2.2.3. Nickel-Metal Hydride
      - 3.2.2.4. Lead-Acid

- 3.2.3. Proximity Sensor
  - 3.2.3.1. Ultrasonic Sensor
  - 3.2.3.2. Infrared Obstacle Avoidance Sensor
  - 3.2.3.3. LiDAR
  - 3.2.3.4. TF Mini LiDAR Laser Range Sensor
  - 3.2.3.5. RPLIDAR A1M8 - 360 Degree Laser Scanner
- 3.2.4. Limit Switches
- 3.2.5. Microprocessor
  - 3.2.5.1. Arduino Uno
  - 3.2.5.2. Arduino Nano
  - 3.2.5.3. Arduino Leonardo
  - 3.2.5.4. Arduino Mega 2560
  - 3.2.5.5. Arduino Due
- 3.2.6. Remote Signal Processing
  - 3.2.6.1. LoRa Shield
  - 3.2.6.2. nRF24L01 RF Module
- 3.2.7. DC Motor Controller
  - 3.2.7.1. Sabertooth 2x25 Motor Controller
  - 3.2.7.2. Syren 50A Motor Controller
  - 3.2.7.3. Arduino Motor Shield R3
- 3.2.8. Motor Blade Controller
  - 3.2.8.1. DROK L298
  - 3.2.8.2. SainSmart L293D Motor Driver Shield
  - 3.2.8.3. Cytron 4 Channel Motor Controller
- 3.2.9. Beacon
  - 3.2.9.1. NEO-6M GPS Module
- 3.3. Parts Selection Summary
  - 3.3.1. Electrical Parts
    - 3.3.1.1. Battery Choice Summary
    - 3.3.1.2. Sensor Choice Summary
    - 3.3.1.3. Microcontroller Choice Summary
    - 3.3.1.4. Arduino Choice Summary
  - 3.3.2. Mechanical Parts
    - 3.3.2.1. Weed Wacker Choice Summary
    - 3.3.2.2. Wheel Choice Summary
    - 3.3.2.3. Chassis Choice Summary
- 4. Related Standards and Realistic Design Constraints
  - 4.1. Related Standards
    - 4.1.1. Electrical Standards
      - 4.1.1.1. Battery Standards
        - 4.1.1.1.1. IEEE STD 1187-2013
        - 4.1.1.1.2. IEEE STD 1188-2005
        - 4.1.1.1.3. IEEE STD 1013-2007
      - 4.1.1.2. PCB and Soldering Standard
    - 4.1.2. Software standards
      - 4.1.2.1. IEEE 829-2008

- 4.1.2.2. ISO/IEC 9899
    - 4.1.2.3. Arduino IDE and Language
  - 4.2. Realistic Design Constraints
    - 4.2.1. Economic and Time constraints
    - 4.2.2. Environmental, Social, and Political constraints
    - 4.2.3. Ethical, Health, and Safety constraints
    - 4.2.4. Manufacturability and Sustainability constraints
    - 4.2.5. Customer Constraints
- 5. Project Hardware and Software Design Details
  - 5.1. Hardware Design
    - 5.1.1. First Subsystem: Power System
      - 5.1.1.1. Overall Power Management
  - 5.2. Overall Integration
    - 5.2.1. Remote Kill Switch
    - 5.2.2. Motor Integration
      - 5.2.2.1. Drive Motor Integration
      - 5.2.2.2. Grass Cutting Motor Integration
    - 5.2.3. Invisible Fencing
  - 5.3. Breadboard Testing
    - 5.3.1. Wire Generator
    - 5.3.2. Wire Sensor
  - 5.4. Software Design
    - 5.4.1. Interface
  - 5.5. Mechanical Design
  - 5.6. Visual Design
  - 5.7. Summary of Design
- 6. Project Prototype Construction and Coding
  - 6.1. Integrated Schematics
  - 6.2. PCB Design and Considerations
    - 6.2.1. PCB Composition
      - 6.2.1.1. Copper Layer
      - 6.2.1.2. Silkscreen Layer
      - 6.2.1.3. Solder Mask Layer
      - 6.2.1.4. Substrate Layer
    - 6.2.2. PCB Vendor
    - 6.2.3. PCB Assembly
  - 6.3. Final Coding Plan
  - 6.4. Project Prototype Testing Plan
    - 6.4.1. Hardware Test Environment
    - 6.4.2. Hardware Specific Testing
    - 6.4.3. Software Test Environment
    - 6.4.4. Software Specific Testing
- 7. Administrative Content
  - 7.1. Milestone Discussion
  - 7.2. Budget and Finance Discussion
- 8. Conclusion

## 8.1. Difficulties

### Appendices

Appendix A - Copyright Permission

Appendix B - Datasheets

Appendix...

## List of Figures

Figure 1: Duke Energy Solar Farm

Figure 2: 1969 MowBot Model

Figure 3: Robomow Model

Figure 4: Tertill Model

Figure 5: Initial Design Flow Chart

Figure 6: House of Quality Key

Figure 7: House of Quality

Figure 8: Basic Linear Voltage Regulator

Figure 9: Basic LDO Regulator Circuit

Figure 10: Basic Switching Voltage Regulator

Figure 11: Buck mode of converter

Figure 12: Boost mode of converter

Figure 13: Transmitter Diagram

Figure 14: Receiver Diagram

Figure 15: Arduino Nano 33 BLE

Figure 16: DSD TECH HM-19 Bluetooth 5.0 BLE Module with CC2640R2F Chip for Arduino and DIY

Figure 17: LoraWAN Web

Figure 18: H-Bridge Motor Diagram

Figure 19: PWM Speed Control

Figure 20: LM2596S Chip

Figure 21: Ni-Cd composition

Figure 22: Lithium-Ion Schematic

Figure 23: Ni-MH Dissection

Figure 24: Lead-Acid Diagram

Figure 25: Example Ultrasonic Sensor with Arduino

Figure 26: Infrared Obstacle Avoidance Sensor with it's components detailed

Figure 27: TF Mini LiDar Pin Configuration

Figure 28: TF Mini LiDar hooked up to microcontroller w/ logic converter

Figure 29: RPLIDAR w/ pin configuration interfaced with an Arduino

Figure 30: Arduino Uno

Figure 31: Arduino Nano

Figure 32: Arduino Mega 2560 Rev3

Figure 33: Transmitted Receiver Diagram

Figure 34: LoRa Shield-915

Figure 35: Arduino & nRF24L01 Integration

Figure 36: Motor Controller Operation Diagram

Figure 37: Sabertooth 2x25 Motor Controller  
Figure 38: Syren 50A Motor Controller  
Figure 39: SainSmart L293D Motor Drive Shield  
Figure 40: NEO-6M GPS Module with 1575-A Antenna  
Figure 41: Battery Trade Matrix  
Figure 42: Sensor Trade Matrix  
Figure 43: Microcontroller Trade Matrix  
Figure 44: Arduino Trade Matrix  
Figure 45: Weed Wacker Matrix  
Figure 46: Cutter location and Quantity Matrix  
Figure 47: Wheels Matrix  
Figure 48: Chassis Material Matrix  
Figure 49: MCU Layout  
Figure 50: Voltage Regulator Design Idea  
Figure 51: Voltage Regulator Schematic Design  
Figure 52: Voltage Regulator PCB Design  
Figure 53: nRF24L01 and Arduino Connection  
Figure 54: Arduino and Neo-6M GPS Module Connection  
Figure 55: NE555 Timer Circuit for A-stable Operation  
Figure 56: Wire Generator Schematic  
Figure 57: Wire Generator PCB  
Figure 58: Op Amp Non-Inverting Amplifier  
Figure 59: Sensor Schematic  
Figure 60: Sensor PCB  
Figure 61: Generator Square Wave Output  
Figure 62: Tank Circuit Output  
Figure 63: Tank Circuit Output with Amplification  
Figure 64: High Level State Diagram for eGoat movement

Might need to change Below Visual design [page 98-ish]

Figure 65: Isometric View  
Figure 66: Exploded View  
Figure 67: Final Block Diagram  
Figure 68: Power Supply testing that old wheel motor works correctly  
Figure 69: Ultrasonic sensor integrated with wheel motor testing  
Figure 70: Alphagoat movement testing  
Figure 71: Alphagoat getting stuck because of swivel wheel  
Figure 72: Ultrasonic sensor hand testing  
Figure 73: Wheel motor testing with relay  
Figure 74: Obstacle Avoidance Testing  
Figure 75: Gantt Chart

## **List of Tables**

Table 1: Final Parts

Table 2: Design, Fabrication and Acceptability Specification

Table 3: Safety Requirements

Table 4: Project Milestones

Table 5: Senior Design 1 Detailed Timeline

Table 6: Estimated Budget

# 1.0 Executive Summary

Solar farms utilize photovoltaic panels to convert sunlight into electrical energy. The solar panels are ground-mounted and sit in a large field with many other panels to collect solar energy. These fields are called solar farms.

Companies like Duke Energy spend upwards of \$200,000 annually on lawn maintenance for each of their remote solar fields. The cost of this is so high because landscape maintenance personnel has to drive over and operate in multiple remote solar farms. Conventional mowing techniques can also be challenging to implement due to these dense and difficult to reach areas. Our project, sponsored by Duke Energy and Orlando Utilities Commission (OUC), is to design and build an automated lawn mower for use at the Disney Solar Farm. While there are various ways to approach this, this project aims to minimize the monthly expenses of ground maintenance by using AI-assisted, autonomous solar powered rover-based robots to articulate and guide electric weed whackers.

An automated mower will greatly reduce the problem of productivity and human labor hours needed to maintain the fields and thus improve overall productivity and financial return. In our design, a power source will drive a microcontroller, along with sensors and motors, that will be implemented in a manner to receive data, and react accordingly. The data being inputted into the system will come from various sensors, such as ultrasonic sensors used to determine location and position. The outputs will result from the microchips script, which will calculate appropriate actions to carry out proper mobility and proper mowing.

This is the next phase of the competition from the original phase 1 that occurred during the 2018-2019 school year. Phase 2 is to focus on the navigation and mobility aspects of the device. The main objective is to complete the 10-foot-wide, by 50-foot-long course working around the obstacles within a 15-minute time constraint. The optimal design will integrate the best technology at the lowest cost. Considerations for safety, reliability, and durability are an absolute requirement.

This report discussed our initial approaches in solving the project needs and outlines the engineering steps necessary to meet the project objectives.

The competitors for this project are the teams from the University of South Florida and the other University of Central Florida teams. All teams were given the same information, specifications, and constraints for the competition.



## **2.0 Project Description**

The issue this project tackles is significant. Not only can this type of device be implemented in solar farms, it can also serve as a residential or country club grass maintenance tool. The success of this device will considerably lower the cost of maintenance to the mere cost of the robot. In addition, this section serves to provide the motivation for developing an automated lawn mower as well as to portray the goals and objectives of this project. Finally, the project requirement specifications will be presented to meet the goals and objectives.

### **2.1 Project Motivation and Goals**

The main motivation for this project is to provide a cheaper alternative for solar farm landscape maintenance. Furthermore, this project strives to demonstrate knowledge gained from years of schooling along with an implementation of this through a functioning device. This project provides an opportunity to work in an interdisciplinary group alongside computer engineers and mechanical engineers. This skill and experience can be crucial in furthering experience in the engineering field.

#### **2.1.1 Project Needs Analysis**

The customers of this project include OUC and Duke Energy. They will be using these robots in order to use around their solar panel farms to minimize manual labor and the use of pesticides that come with grass upkeep. If their needs are satisfied, this robot can allow them to switch from their current methods of maintaining the grass in the solar farm fields around the solar panels, to using autonomous robots which will save hundreds of thousands of dollars. While this project is a competition and the needs more so focus on the competition aspects, the best highlights of the products can then be taken and implemented into OUC and Duke Energy's final solution design.

For this competition, these sponsors have provided a list of needs that the E-GOAT is to satisfy. These needs include that it must be autonomous, able to avoid obstacles, is battery operated with rechargeable batteries, within 24"x24"x20" dimensions, cuts grass between 3"-6", has a kill switch both physically and remotely, is within \$1500, traverse vertically 3" over 2' horizontal span, and can cut a 10'x50' section of grass within 15 min. These needs were collected through provided documents on goals of the competition as well as through communicating with our sponsors for clarifications on their wants.

A field site visit was also conducted in order to take measurements and see the layout of the competition to know what extra challenges our robot may have to face. In **Figure 1** below you can see the layout of the competition field. The 50ft by 10ft area each team will need to complete includes one line of solar panels to need to traverse around. Where the dead grass is where currently pesticides are sprayed to kill the grass. The purpose of these autonomous lawn mowers will be to eliminate the need of using grass killer so long as the robot can successfully maneuver and cut the grass instead.



Figure 1: Duke Energy Solar Farm

The main challenge of the competition with the customers needs that were listed above will be finding a solution that will be the most efficient to maneuver around the solar panel legs and still cut the grass between them at the required heights.

By the end of this project, this product can benefit more than just the sponsors hosting this competition. If successful or better than the current autonomous lawn mowers out there, it can then benefit multiple industries from homeowners, to golf courses, to businesses and so on by providing a product that is useful and can save time and money on the typical landscaping maintenance.

Once having the customers needs, the remainder of this report will elaborate on the research done too help meet these needs, requirements made, and the process at which we began to choose specific components we decided on for our design to satisfy both the needs and requirements.

## **2.2 Objectives**

In designing our project, our main goal was to design and build an AI-assisted, autonomous rover-based robot to articulate and guide electric weed whackers. We plan on completing this as efficiently as possible. In further detail, this can be attained by efficiently by identifying inputs, sorting and processing them, and directing proper output actions. Our device will think through these conditions using proper code commands and execute them accordingly through our chosen processor.

A main component of our project is to provide the articulated motion needed to move the weed whacker across the terrain and cut grass. Likewise, consideration of various powered trimmers is necessary. This motion can be achieved in different ways with different location placements of the trimming motors.

A few more necessary features our device must process include identifying which grass areas need attention, avoiding obstacles while navigating, and provide overall motion control of the rover-based robot. This could be done through ultrasonic and infrared sensors. These sensors can detect an object's distance, which in turn can assist navigation. Additionally, multiple ultrasonic and infrared sensors can be displaced around the perimeter and in specific locations to collect data. This data can be processed and help the robot determine the difference between grass and obstacles. Motion control can be done through controlling motors that propel the robot forward and backward. The rover-based robot will need to drive through the course effectively covering the entire field.

Grass cutting may take place at night while it charges during the day. To accommodate such conditions the system must use a defined battery storage with charging capabilities. This brings us to another goal of the project. Having a power supply with maximum storage, great charging capabilities, and low cost is essential. Further research regarding this will be discussed later on.

## **2.3 Existing Similar Projects and Products**

Though the market for automated lawn mowers isn't vast, it has been around since its first documented attempt in 1969. This design was named the MowBot. Aside from the MowBot, the next few subsections will contain research and discussion regarding different automated lawn mowers and similar products.

### 2.3.1 MowBot

The MowBot, **Figure 2** below, was the first attempt at an AI-assisted self automated lawn mower. It was created by S. Lawrence Bellinger in 1969. It was commercially marketed at \$795, and was said to be autonomous and cut randomly within the confines of an installed guidewire. The MowBot could also cut 7,000 square feet on a single charge.

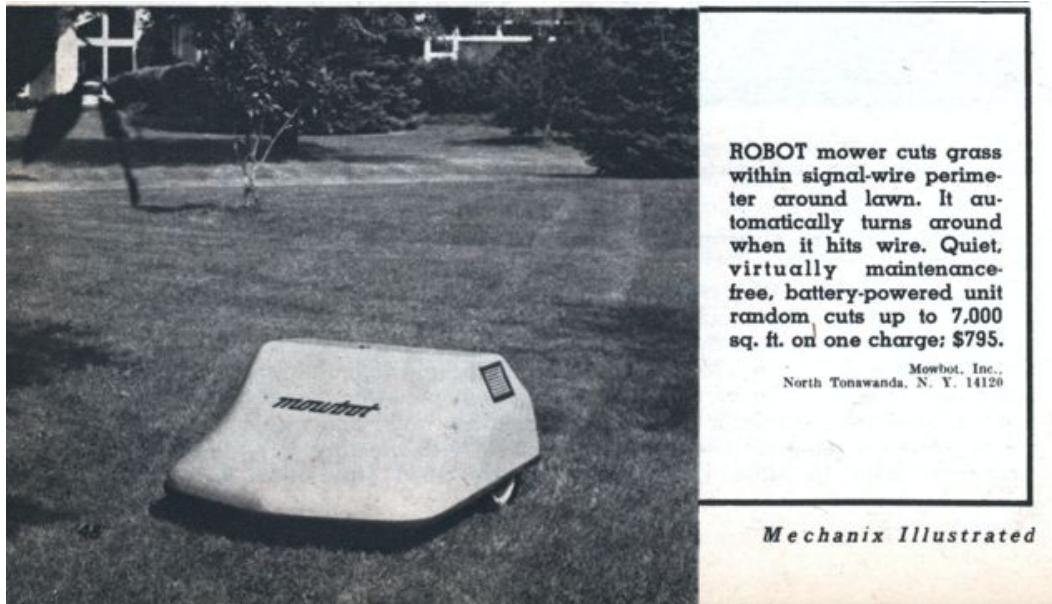

Figure 2: 1969 MowBot Model

Since 1969, robotic lawn mowers have become more and more sophisticated. The later models are self-docking and contain sensors that detect various obstacles, elevation, rain, and other environmental factors. In 1995, the first fully solar-powered robotic mower became available. Some models also have the capability to connect with custom phone apps, so the user can schedule mowing times and frequency, as well as manually control the mower with a digital joystick. According to a Bloomberg financial article, the rise of robotic lawn mowers can best be showcased by the fact that in 2012 the sales of robotic lawn mowers was 12X that of traditional styles. Particularly in European countries, they are the fastest-growing garden tool.

### 2.3.2 Ryobi Model RY40109

Before we consider some obvious mechanisms that are needed for automated control, we have to come up with a sustainable, efficient power system. The Ryobi Model RY40109 is a great place to start. The design has a 40V rechargeable, replaceable battery that powers the motor to spin the blade. The

wheels are driven by a variable speed motor that is adjusted using a switching mechanism. Moreover, this device has several mechanical and safety features that are included to shut the blade down in case of emergency. The important thing to take from the model is that it is self-propelled, meaning the division of battery power is critical to understand.

This is an important piece of equipment to understand. The replaceable and rechargeable battery has the power to cut what is needed, from grass to light yard waste, but also run the wheels over grass and dirt effectively. This means that the gearing in the system has to transmit plenty of power to run both. Because of this, this model represents an excellent 'power train' system.

### **2.3.3 Robomow**

Robomow's latest design, **Figure 3** below, Robomow RS622 Robot Lawn Mower, is one of the more expensive automated lawn mowers. This design claims the newest technology, making it a complete and perfect robot for mowing your lawn. It was created to climb up to 36 degree slopes and has the ability to mow up to 4 zones individually in your garden. The mowing height is easily adjustable and has a special blade design and unique edge mode. Due to the requirement of a string cutter, we will be unable to use a blade cutter.

If we take a deeper look into the Robomow, we can apply some of their design techniques into our project. Some of the disadvantages of this model include the cost of purchase, the initial setup/preparation, and the unusual scheduling method. Depending on the size of the lawn, you'll spend a good chunk of time setting up the system and installing the perimeter wire to prevent the mower from wandering off the yard. Once this setup is complete, the Robomow does a fantastic job of keeping the lawn in top shape. The main issue here is the perimeter guide wire. Our project plans to complete a system capable of determining boundaries without the use of guide wire. This can be done with implementing sensors to determine location underneath the solar panel. Something to take from this project is the control panel and LCD display on the top of the mower. This can display battery life, time and date, and current status of operation.



Figure 3: Robomow Model

### 2.3.4 Tertill

Lastly, another product to review is the Tertill. In **Figure 4** below, the Tertill is solar powered and its main purpose is to keep a small garden (typically less than 200 square feet) weed free. It can tell the difference between weeds and plants due to their size. Plants that are too short to reach the Tertill's edge are assumed to be weeds. By continuously roaming through your garden, the Tertill ensures no weeds by preventing would-be weeds from germinating by shifting the soil around. However, if weeds do manage to grow, the Tertill will whack these weeds using a spinner string trimmer, which cuts the weed off near the ground. Continuously roaming prevents weeds from every growing taller than the Tertill. Similarly, there is a guide wire to contain the Tertill in the garden. Positive things to take from this include the cambered tires design and the sensors that check for plant height.

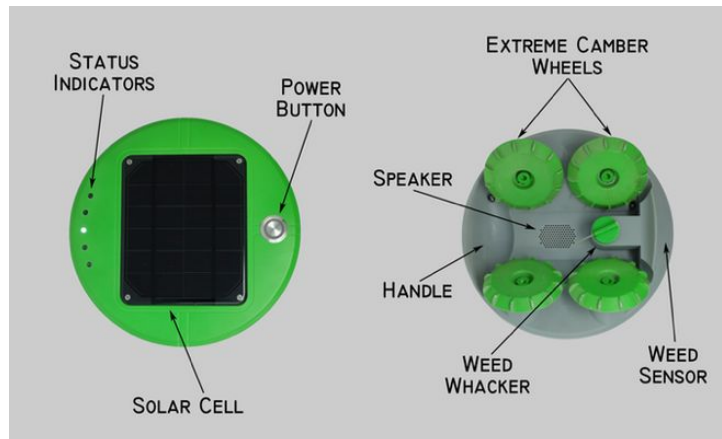

Figure 4: Tertill Model

## 2.4 Requirement Specifications

Below are some requirement specifications sent over directly from Duke Energy.

- Robotic rovers must use an off-the-shelf battery powered trimmer (no metal blade – must be string-based) to cut grass.
- The rover may consist of an off-the-shelf remote controlled system that is modified for the application but should still have an autonomous mode or capability.
- The robotic grass cutting rovers must be equipped with a remote kill switch that can turn off the cutting system and locomotion at a distance of approximately 50 feet.
- An off-the-shelf battery and charger must be utilized.
- The rover must be capable of safely navigating in uneven terrain (~ 3 inch terrain differential over ~ 2 foot span in any direction) without capsizing while avoiding a series of obstacles.
- No part of the system must be of a height no taller than 20 inches from the ground.
- The system must operate independently and have no attachments to existing solar farm array structures.
- Total system materials and assembly cost target: \$1500.
- The ability to cut grass at an acceptable height (3 to 6 inches) is considered a plus. It is expected that teams will adapt and mount a commercially available string trimmer head to their devices.
- The system must traverse the large areas and maneuver around PV support structures.
- Avoid any damage to surrounding infrastructure, the environment and humans.
- Provide a math model to estimate how much grass area the robot can cut per hour. Teams will be provided total size of a typical solar farm. Assume grass cutting of entire site on a monthly basis and provide analysis based on season/weather/location for purposes of this evaluation.
- System to provide a secondary safety protocol to deal with rogue objects, in addition to the remote kill switch. Potential concepts might include; GPS with boundary kill and/or installed invisible fence with secondary kill protocol when crossed. System also to include location beacon with independent power supply (the beacon should be able to operate for a defined period of time after the main battery is completely drained).

In addition to these requirements, the main purpose of this design is to focus on the navigation and mobility aspects of the robot. We are able to use previous



designs in this phase. However, our project is starting from scratch as we think this is the best way to implement our ideas.

Furthermore, some other things we must bring our attention too are listed below. In order for our system to work completely and efficiently, we must examine:

### **2.4.1 Mechanical Considerations**

The baseframe of our device needs to be able to withstand the load of the vehicle components. These would include attachment the wheels, a cover container that will hold the electrical components, batteries, motors, and trimmers. The geometry of the chassis needs to be chosen so that it can carry all components as well as provide the proper width to the trimmer cutting range. This frame must be resistant to water and corrosion.

Our rover-based robot will move with motors. The motors used in our design must be able to generate enough torque to get the vehicle to move on inclined terrain. The motors also have to be able to alter the direction of the robot. This mechanism will be used in turning and avoiding obstacles. Lastly, the motor has to have enough power to rotate the wheels on the robot to drive the vehicle.

The wheels of the machine have to have enough traction to move in grass, dirt, and mud. The wheels must have the appropriate tread to provide mobility in all directions.

The cutters attached to the robot have to cut the grass to a maximum height of 3". In addition, it must be Nylon string based. Covers will be present to protect the outside environment from cutting trimmers.

### **2.4.2 Competition Scoring**

Lastly, the design competition scoring considerations are below.

**Design Documentation:** Complete drawing package including component drawings to scale and with dimensioned assemblies for any fabricated parts, parts list (BOM), wiring diagrams, and programing for any custom coding. Should also include final assembly drawings for the complete system for manufacturing.

**Presentations:** Each team must be prepared to give an oral presentation of their project. The intent is to have a short, concise, description of the project and it



may be based on the team's Capstone presentation materials. More details will be given prior to the competition.

**System Modeling:** Complete modeling of operation and charging, including grass area cut per charge and time to charge. Modeling of estimated quantity of robot systems and annual costs to maintain a typical solar farm. Calculations of battery life.

**Navigation and Mobility Speed and Accuracy:** Given an area of 50'x10' with the objective to cut the entire area in 15 minutes. Main scoring criteria will include percentage of total grass area cut and time. The course will be demarcated by use of a marker such as a wooden stake or traffic cone. If needed, individual teams can supply additional boundary marking device(s), however, no modifications to panel and/or support structures or surrounding land is allowed. Secondary scoring criteria will include cut height, uniformity of cut.

**Obstacle Avoidance:** Team will be provided an area of 4 posts of an array. Additional obstacles may be added, including cinder blocks and a mock up that will represent a person on site. Points will be given for teams that cut closer to obstacles without damage to the obstacles or the robot system.

**Safety and Risk Management Plan:** Quality of response to risk issues and procedures for the robot system to move to a safe location away from panels when an issue is identified.

**Cost Estimate:** Complete analysis of system cost including calculation of system weight.

**Other Requirements:** Each individual University or Department may choose to impose additional requirements on their students as part of their credit course requirements. Such examples may include the design and construction of specific components, modeling of specific systems, etc. Such additional requirements will not be part of the judging criteria for the purposes of the competition. Please consult your faculty advisor or professor for any specific requirement that applies to your particular University or Department.

Again, the competitors for this project are the teams from the University of South Florida and the University of Central Florida teams. All teams were given the same information, specifications, and constraints for the competition.

## 2.5 Initial Block Diagrams

In **Figure 5** below, is the preliminary examination of who within our group will be in charge of what section of our project, with each one being acquired, or built during Senior Design II.

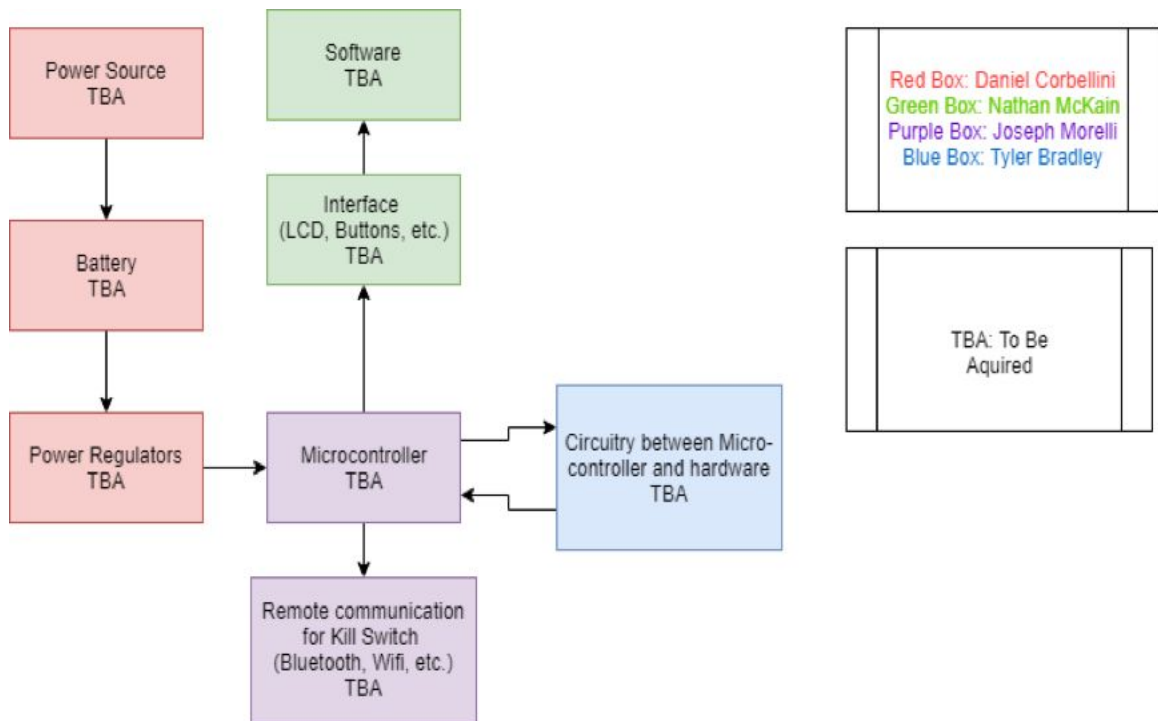

Figure 5: Initial Design Flow Chart

## 2.6 House of Quality Analysis

The House of Quality is comprised of five portions. The first component is the consumer requirement section. In this section, the consumer voices their wants and needs along with their relative importance. The second portion is the functional component section, which lists requirements deemed necessary and technically feasible by the group members. The two were then compared to one another to determine which functional requirements relate the most to customer requirements, which makes up the third portion of the chart. The fourth section consists of the relationship between the functional requirements and functional components, referred to as the “importance rating sum”. This portion essentially determines the relative importance of individual components to each requirement

in order to ascertain the components that carry the most weight in the project. The fifth and final portion of the House of Quality is the roof section, which describes the relative correlations of each engineering component to the others. This is important to ensure that the needs of one component do not negatively affect or eclipse those of any other.

Pictured in **Figure 7** below is the House of Quality generated for this project. Along with the key for the House of Quality in **Figure 6**. After completion of the chart, it was determined that the most important factors the group needs to meet are:

1. Robot moves autonomously
2. Robot detect and avoids obstacles
3. Robot can be shut off (whether it be with a remote or physical switch)
4. Robot is able to cut grass

Direction of Improvement	
Maximize	▲
Target	□
Minimize	▼

Relationships		Weight
Strong	●	3
Medium	○	2
Weak	▽	1

Figure 6: House of Quality Key



## **3.0 Research Related to Project Description**

This section of the report focuses on existing products that are in our market as well as researching relevant technologies and possible strategies that could be used in our design. There are many similar products out there that we can study and learn from. Many different methods have been implemented to complete this goal. We will take a look at various systems that try to build an automated lawn mower and try to create our own design determine what approach

### **3.1 Relevant Technologies**

Aside from entire systems, it can be beneficial to consider relevant, individual technologies on their own. This section will assess different technologies or ideas in their relevant fields. Each component that was researched was considered or is being used in our design. The technology assessments were researched in areas of value including safety, design, complexity, cost, and past works to name a few. In order to ensure proper component integration, in-depth analysis of the following topics were performed.

#### **3.1.1 Batteries**

Generating power for the rover, or any electronic device, is an integral part of the design process. Should there not be enough power to be supplied to the components that need it the project will not function correctly, or function at all. This is the purpose of batteries. There are a multitude of battery designs being manufactured and they are categorized into two types, primary and secondary batteries.

#### **Primary Batteries**

Primary batteries are batteries that, once depleted, cannot be recharged. This is due to the electrochemical reaction that happens within the cell cannot be reversed, making the battery a one time use. Examples of such batteries are AA, coin cells, and similar batteries. They are best used for systems designed for low energy consumption. Alkaline batteries are the best composition for primary batteries since they have a high specific energy, unfortunately they don't have a high load current, thus cannot be used efficiently with systems that require low current. Due to one of the engineering requirement specifications, being that the EGOAT needs to be rechargeable, we will not be using a primary battery.

## **Secondary Batteries**

Secondary batteries are batteries that can be recharged once the cell is depleted. These types of batteries are used with devices that have high drain appliances, where single use batteries would be too expensive and impractical to use. They are the more cost-effective option of the two types of batteries in the long run. Secondary batteries can be broken into four sub-categories based off of their chemical compositions:

- Nickel Cadmium (Ni-Cd)
- Lithium-ion (Li-ion)
- Nickel-Metal Hydride (Ni-MH)
- Lead-Acid

### **3.1.2 Sensors**

The sensing and perception portion of the system will collect, fuse, and interpret data from local sensors. In order to properly navigate the course, we will have to implement sensors to collect data. A few important sensors to consider are the ultrasonic sensor, the infrared obstacle avoidance sensor, and the LiDar. When looking at these three sensors we considered the use cases of each of the sensors and finding which one worked best for our use case.

#### **3.1.2.1 Battery Temperature Sensor**

Due to environmental and load factors the battery of the eGOAT could be operating at a maximum load situation and be subjected to high temperatures. This could lead to degradation of the system's battery, affect incoming and outgoing power and ultimately the quality of power. A Battery temperature sensor would help lower the voltage when the battery's temperature is too high, and increase the voltage when the temperature is low. The changes in voltages would be made through conditions written through us. It really is just a gauge for us to understand how the rest of the system's functions are affecting the battery condition. The temperature thresholds would be determined by the data sheet or recommendations of the battery manufacturer.

### **3.1.3 Autonomy**

The problem this project aims to solve revolves around a semi-autonomous system. In order to achieve this, our machine will include a programmable logic controller that is capable of responding to data obtained from various sensors.

This autonomous system will have a preset script that makes decisions based on sensed data. Ideally, our eGoat will be to path through the solar panel zone on its own and identify the differences between grass areas that do and don't need cutting, and the legs holding up the solar panels. An in depth analysis of different microcontrollers will

### 3.1.4 Power Sub-System

Each circuit and subcircuit requires a specific voltage, current, or power to run as designed. When operating out of range of the input, the output will also become distorted. On top of that, several sub systems operate best under their own conditions. Aside from different designs for various voltage converters, PCB layout will be discussed in the following sections.

### Linear Voltage Regulator

Linear voltage regulators, **Figure 8** below, must be used in order to maintain a steady voltage. The resistance of the regulator varies in accordance with the load we put on it, resulting in a constant output. It uses a closed feedback loop to bias a pass element to maintain a constant voltage across its output terminals. They also only work as step-down converters, meaning the voltage sent out of it will always be less than the voltage sent in. That difference in voltage is called the drop-out voltage. Power is dissipated in the pass transistor of the circuit. This power is also wasted as heat and can negatively affect the regulator.

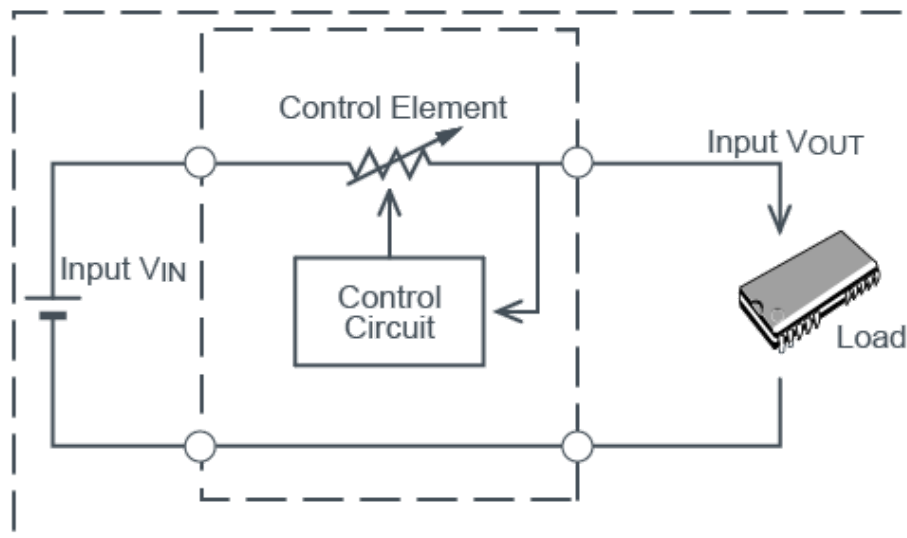

Figure 8: Basic Linear Voltage Regulator

Advantages of this type of regulator is that they have simple circuit designs, few external parts. Linear regulators can be made to do a variety of things. They can have fixed outputs, outputs programmable by resistor divider, can regulate negative voltages, or be low-dropout regulators. Some can even be made to include battery smart charging technology. Some drawbacks on linear regulators is that they have a tendency to have over-temperature shutdowns, have relatively poor efficiency, and can only be used as a step-down.

## Low-Dropout (LDO) Regulator

The Low-dropout (LDO) voltage regulators are different from the other regulators due to their configuration. They consist of only one PNP transistor, as shown in **Figure 9** below.

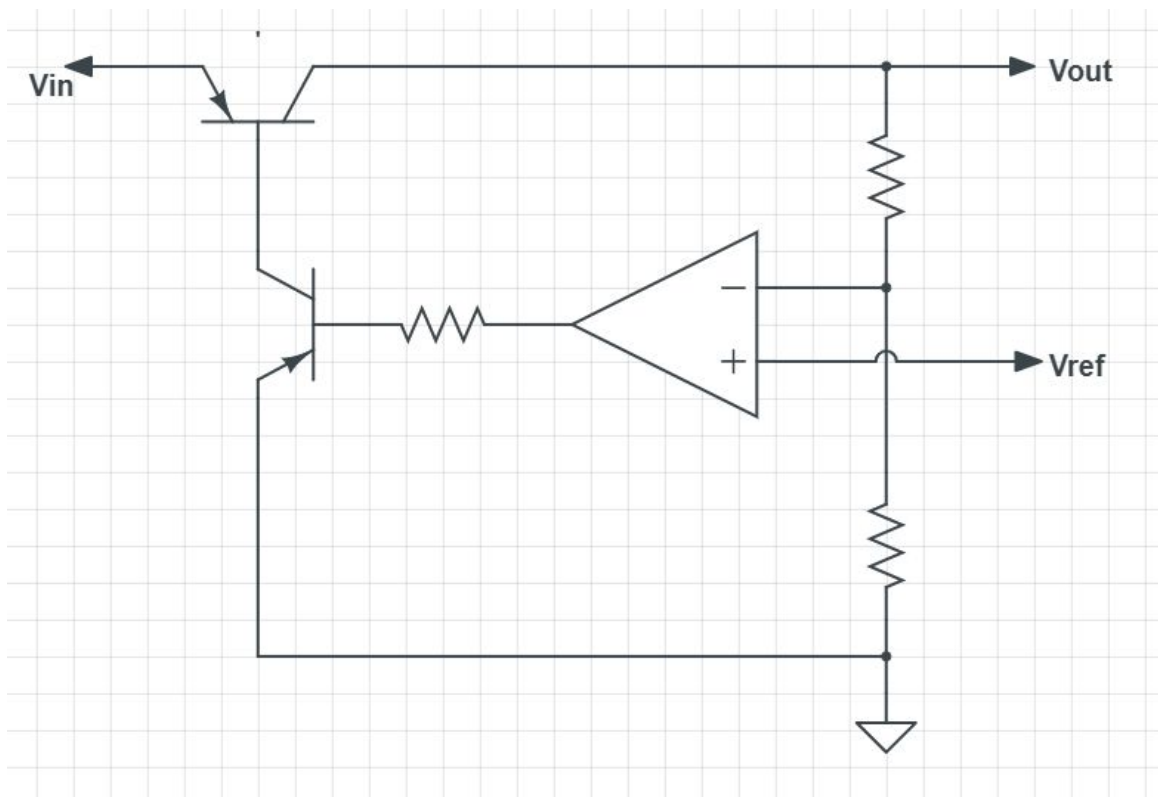

Figure 9: LDO Regulator Circuit

The low-dropout voltage regulator's advantages are its simplicity in its design, there isn't any switching noise within the device, as there is no switching occurring within it, and the size of the device. Low-dropout voltage regulator's are also useful as they have the ability to maintain its regulation at low voltages, where, even at full current the voltage is usually less than 1 volt across the



transistor. These circuits are the reason that most commercial electronics that are battery-operated use LDO voltage regulators. One negative of the LDO voltage regulator is that it has to dissipate power across the device to regulate the output voltage, and thus it can generate a decent amount of heat.

## Switching Voltage Regulator

Another option is to use a switching voltage regulator. As shown in **Figure 10**, These types of regulators use a switching element to transform the incoming power into a pulsed voltage, which can be smoothed into a better waveform using capacitors, inductors, and other elements. The benefits of using the switching voltage regulator is that it has high efficiency, low heat generation, and can be used to boost or buck voltage, even with the negative operation.

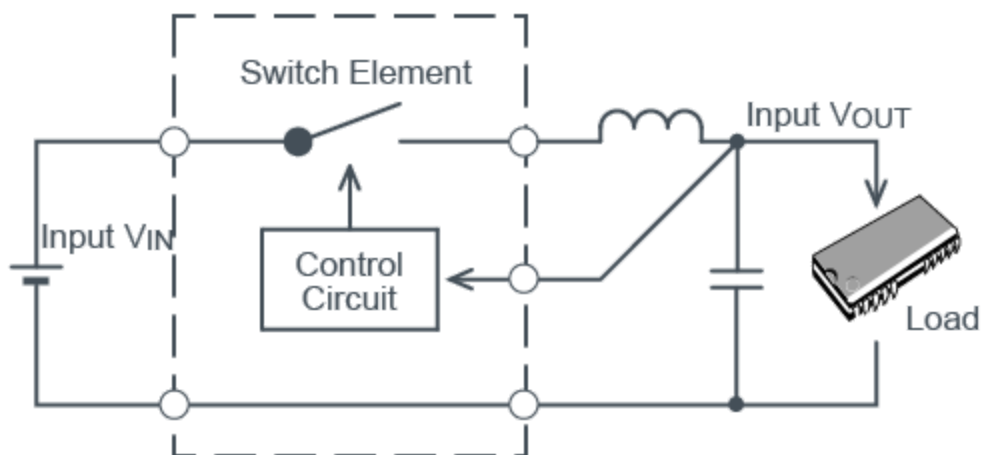

Figure 10: Basic Switching Voltage Regulator

It has lower heat generation because the power is supplied from the input to the output by turning ON a mosfet acting as a switch until the desired voltage is reached. When the wanted value of voltage is reached it will then turn OFF and use no power. The downsides that must be known when using this type of regulator is that it produces more noise, has a more complicated design, and has more external parts.

## Boost/Buck Converter

Buck-Boost converters are a form of switching-mode power supply that can supply a regulated DC output from a source voltage either above or below the desired output voltage. Using this converter is very helpful in battery-powered designs where the input voltage is above the output voltage, but declines as the battery starts to drain and lose charge. As stated in the name, it can be used as a buck or boost converter, and can operate with AC or DC input voltage sources. The buck converter, **Figure 11**, can produce a DC output between 0V and just below the input voltage.

Common applications of boost/buck converters is systems where the input voltage is high, such as 48V, and has to be lowered to 12V to be used by a board. The boost/buck converter would be used for this conversion, but if the board required a few smaller voltages it would be produced by other converters. Boards may require many different voltage amounts so using this to start with a higher voltage can be advantageous.

The boost function of the converter, **Figure 12**, can produce an output voltage higher than the input voltage. By switching the circuit between the mode that stores energy in an inductor while a capacitor supplies the output and one that releases that stored energy in order to recharge the capacitor. When the current that is going through the inductor is cut off, the energy stored in its magnetic field gets released in high-voltage pulse as the field collapses, and the resulting current is sent to a capacitor to raise the output voltage.

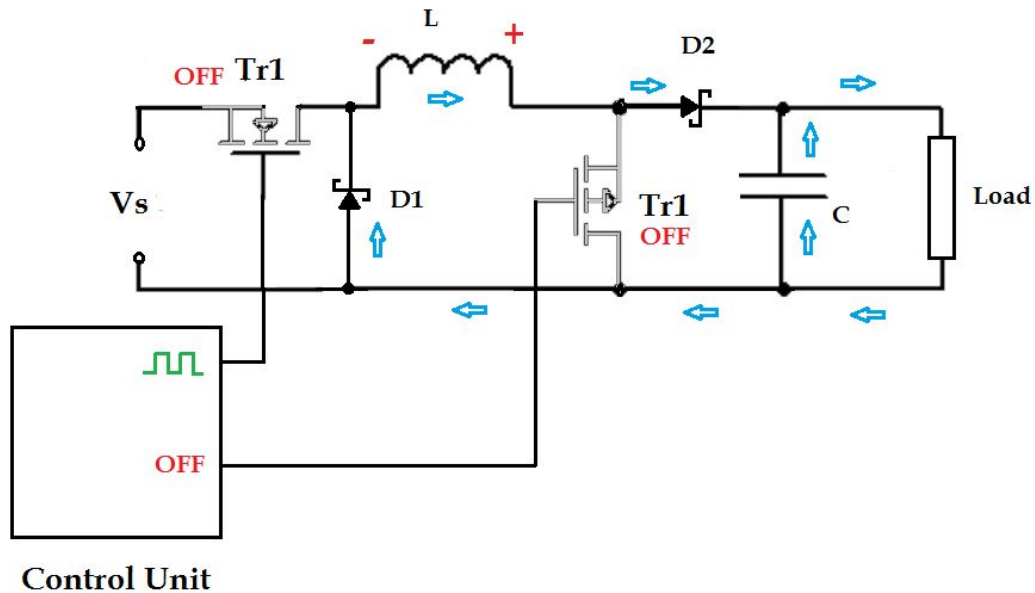

Figure 11: Buck mode of converter

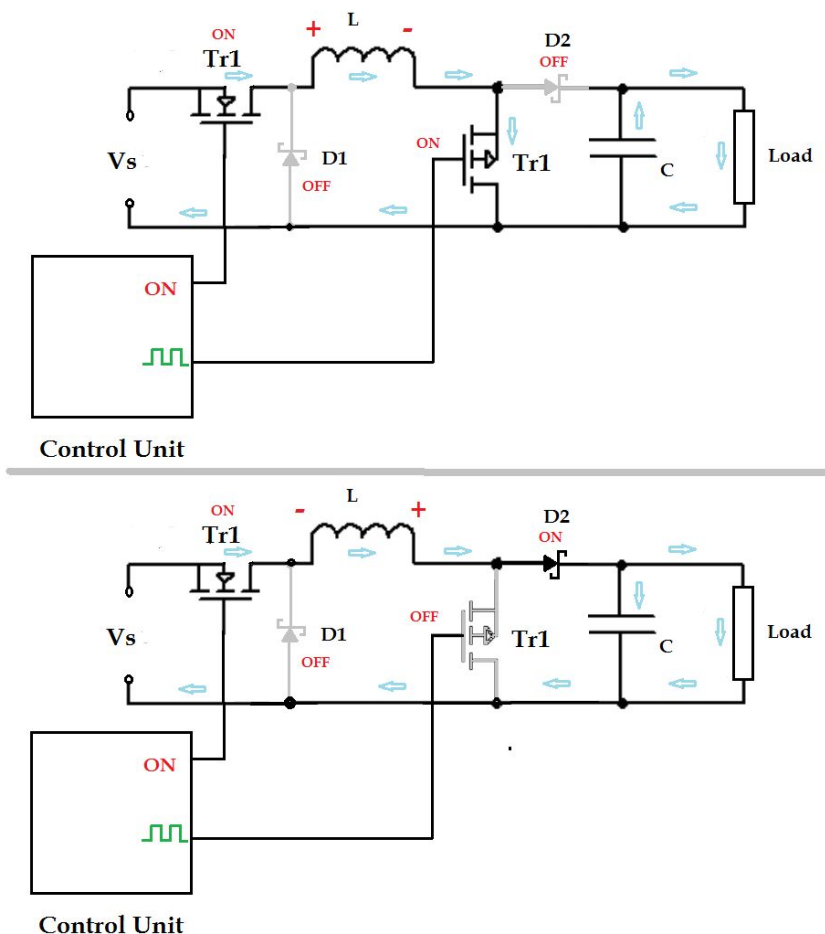

Figure 12: Boost mode of converter

### 3.1.5 PCB Layout

PCB Layout is one parameter that the IC makers can't control. There can be serious dangers without the right design. When constructing our PCB layout, we have to maximize the copper surface area for higher currents. Although our project won't contain such extreme currents, this is something important to consider for all future designs.

High current electronic components like microcontrollers can generate a significant amount of heat. These types of components perform best near the

center of the PCB. If it is near the edge, the heat will accumulate and the local temperature will rise. However, if it is placed near the center, the heat can diffuse throughout the entire board and the total board temperature will be lower. If there are multiple high electric components, it can also be beneficial to space them out around the PCB rather than clustered in the center.

### **3.1.6 Communication Hardware System**

The main purpose in having a communication system in our design is to provide a remote kill switch. As discussed earlier, the remote kill switch will power off the device from a distance as a safety precaution. Common communication systems work off two major devices. A transmitter to send the signal and a receiver to receive the signal. Aside from this requirement, an electronic communication system can benefit our project by having a remote display of different statuses in our system such as battery life, current mode, and current location. These different values can be communicated through Android or iOS app. Depending on the route we choose for a kill switch there would be many ways to implement it.

#### **Transmitter**

A radio transmitter consists of several elements that work together to generate radio waves that contain useful information. Every transmitter contains a power supply, oscillator, modulator, amplifier, and antenna, as shown in **Figure 13**. The power supply provides the necessary electric power to operate the transmitter. The oscillator creates an alternating current at the frequency on which the transmitter will transmit. The oscillator generates a sign wave, which is referred to as the carrier wave. Now that we have our carrier wave generated, we can use the modulator to add useful information to this wave. The two most common ways to encrypt a message in the carrier wave is through amplitude modulation (AM) and frequency modulation (FM). AM makes slight increases or decreased to the intensity of the carrier wave while FM makes slight increases or decreases to the frequency of the carrier wave. The amplifier amplifies the modulated carrier wave to increase its power. The more powerful the amplifier, the more power the broadcast. Lastly, the antenna converts the amplified signal to radio waves. Understanding how a transmitter functions is important and will help in deciding which transmitter to select.

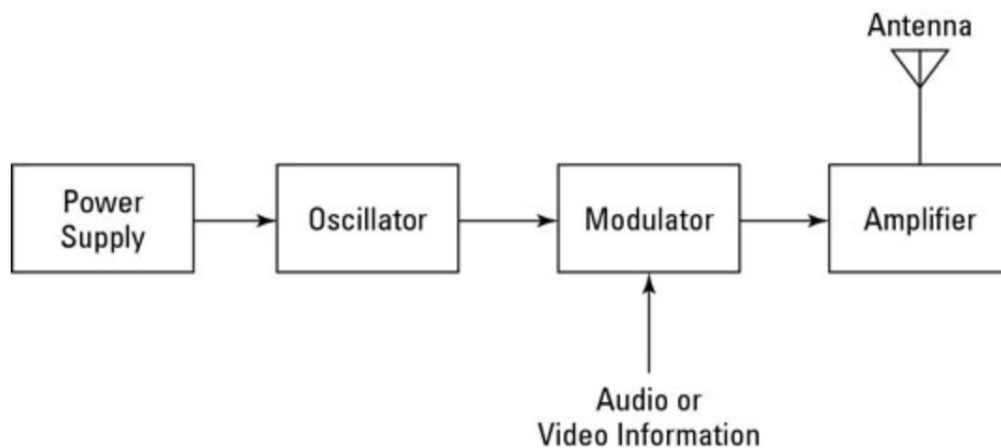

Figure 13: Transmitter Diagram

## Receiver

Radio receivers basically work in a reverse manner of the transmitter. The process line for a receiver uses starts with an antenna to capture the radio waves shown in **Figure 14**. The antenna is usually a length of wire that, when exposed to radio waves, induces a very small alternating current in the antenna. Next, a sensitive amplifier amplifies the small signal to a signal that can be processed by the tuner. The tuner and detector now come in to play an important role in the receiver circuit. The tuner extracts signals of a particular frequency from a mix of different frequencies. Essentially, the antenna captures radio waves of all frequencies and the amplifier amplifies all of them. The tuners role is to select which radio waves to pay attention too. The two most common ways to filter these frequencies is through an RC filter circuit or an Op Amp filter circuit. Both of these methods can design the common three types of filters. A low pass filters blocks frequencies higher than the desired cutoff frequency. A high pass filter allows frequencies above the cutoff frequency. Finally, a bandpass filter allows frequencies slightly above and slightly below the center frequency. It blocks all frequencies that are a certain distance from the center frequency in either direction. The next step in the process is the detector. The detector is responsible for separating the information from the carrier wave. In an AM signal, this can be done with a diode that rectifies the alternating current signal. What's left after the diode has its way with the alternating current signal is a direct current signal that can be fed to an optional final amplifier stage. This last stage can amplify the signal if its too weak, but is not necessary.

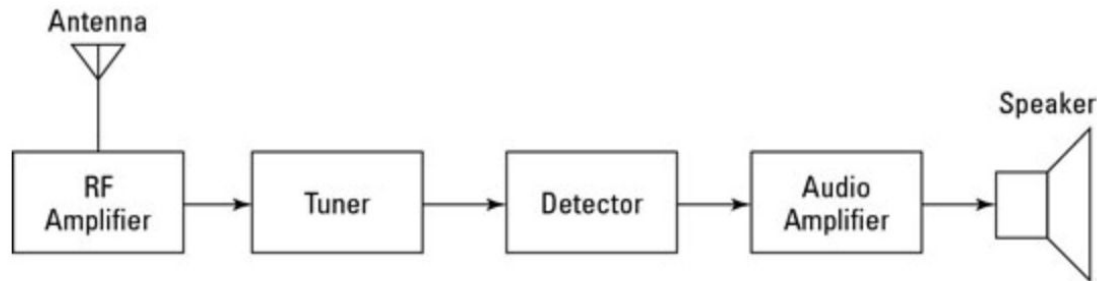

Figure 14: Receiver Diagram

### 3.1.7 Communication Methods

There are many methods to choose from in order to carry out our remote kill switch signal. Advantages and disadvantages of several different implementations will be discussed later on. A very common mode of communication between devices is through 2G/3G (GSM) or 4G internet. This style can have extreme range between devices but runs at the cost of handling interactions between millions of devices and the power consumption needed to operate communication towers. A similar method of communication with extended range is long range and local WiFi. This type of style uses larger antennas to increase distance connectivity opposed to local WiFi routers. Likewise, this requires some sort of tower to ensure the signal can travel as needed. Lastly, we will consider Bluetooth because it focuses on low power requirements with relatively close range, small capacity devices. This style can be considered the opposite of GSM connection.

We will consider all these technologies and compare which device runs most efficiently with the least cost. Although some styles can do the job better, it is unnecessary to go overboard with short range communication. In the end, we are only trying to send simple commands, a remote kill switch, and data from the device over a short distance.

### WiFi Communication

The first channel method we considered for a remote kill switch is WiFi communication. There are many different implementations of WiFi and discussing all the variations is beyond the scope of this project. However, we will discuss two groups that cover what is needed for our project.

## Local WiFi

Local WiFi , or wireless LAN, communication is probably the most recognized type of utility. It is becoming more and more common for modern systems to include built in WiFi capabilities. Most computers and microcontrollers can implement almost anything up to an IEEE 802.11ac connection. Local WiFi is also extremely useful for local diagnostics and testing. In addition, the chosen Arduino microcontroller for this project has WiFi modules as does most computer and this could be used to create a local network between the two.

### Advantages

- Extremely cheap
- Extremely high data rate processing
- Moderate power usage
- Personal laptop convenience

## Long Range WiFi

Long Range WiFi is a specialized adaptation of the normal protocol built for extreme ranges. Traditionally, this type of communication requires an antenna on a typical access point to extend the range to lengths of around 300 km. Although the cost of this isn't much (~\$25), it draws a rather high current and is not suitable in our design.

## Bluetooth

Bluetooth is a controversial technology in that it is sometimes a better fit for some applications rather than others. Bluetooths goal is to exchange a lot of data at close range with the devices being used able to send and receive data. Bluetooth wireless communication has become very common and popular for how small, low powered peripheral devices. Starting with bluetooth v2.1 ranges of bluetooth can reach up to 100 meters, the same applies to bluetooth 4.0. With the introduction of bluetooth 5.0 however ranges can now reach up to 400m. It is also worth noting that starting with bluetooth 4.0, bluetooth is now low energy and all versions of bluetooth ranging from bluetooth v2.1 up to bluetooth 5 use the IEEE 802.15.1 network standard. The one issue with bluetooth that we could face is that range depends heavily on radio performance, surroundings, as well as antennas. Other factors include the transmitters output power, the receivers sensitivity, and the physical objects in the transmission path. Radio performance and antennas are more set when the bluetooth chip is bought, this has little room

for change. This is a situation where we will need to know the expected radio performance and the antennas we are getting with the bluetooth module we buy. What can heavily affect the range of bluetooth is obstacles and objects in the path of the transmission.

The use case of bluetooth in our egoat could vary in a wide range of ways. If we use bluetooth with our main arduino mega than we can create an app that can control the robot remotely. This app can have functionality that has the robot turn and could potentially act as a wireless remote control for the egoat. Even if we don't make a whole separate mobile application to utilize the bluetooth connection, a simple bluetooth remote could be paired and used as well to achieve the same end goal. A for sure use case for bluetooth would come in the form of working with the kill switch. Whether a mobile app is made or a seperate remote is used bluetooth would be a great way to act as a way of communication for the kill switch.

To get bluetooth capability for the arduino it wouldn't be hard either. Our group has the choice of buying an arduino with a built in bluetooth chip like Arduino Nano 33 BLE chip shown in **Figure 15**. This arduino is cheap starting at only \$19 and functions just like a normal arduino nano but with the addition of bluetooth 5.0 on board. This gives an edge in that we wouldn't need a whole separate part and it would be easier to use out of the box when it comes to programming it.

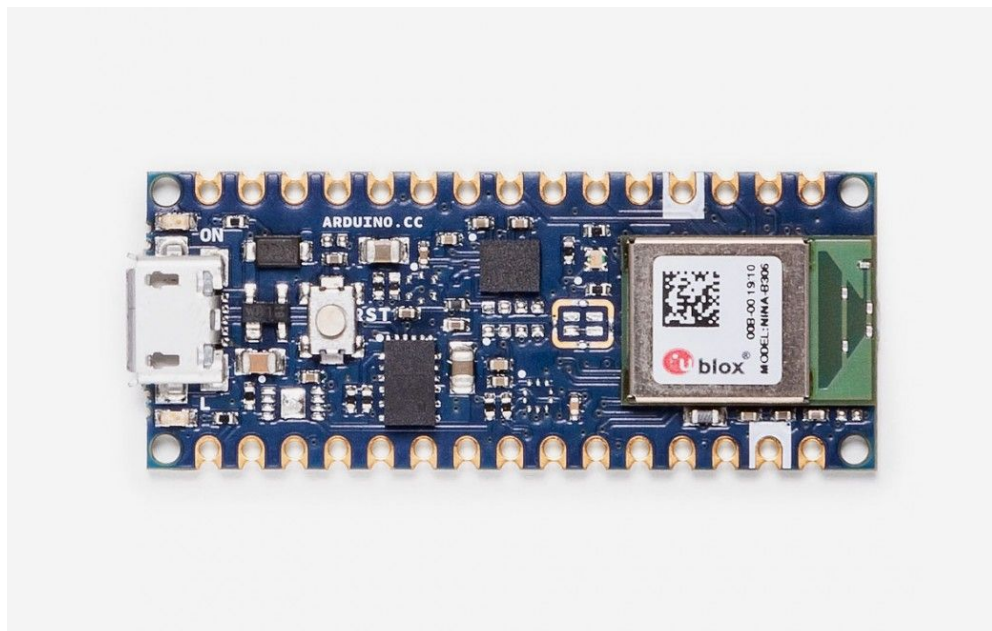
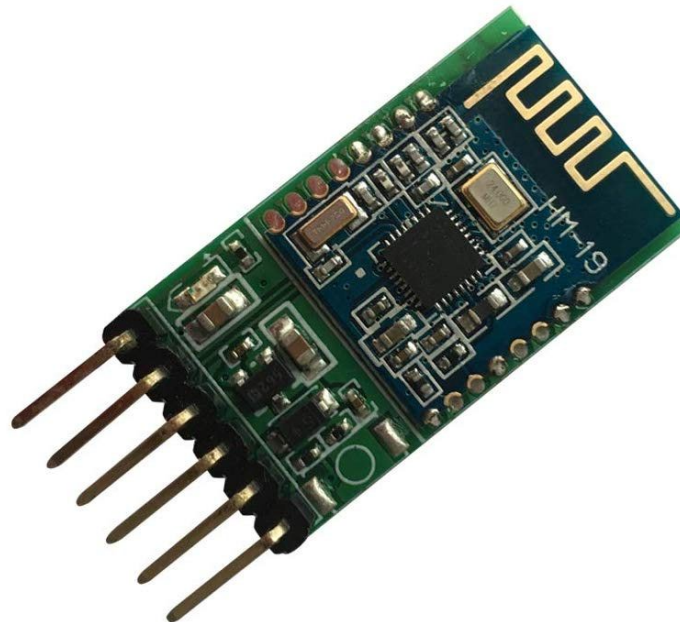

**Figure 15: Arduino Nano 33 BLE**

If we decided to go a different route and get an arduino without built in bluetooth functionality like we are with the Arduino Mega, that wouldn't be a problem either.



There are plenty of bluetooth chip add-ons that can be used to give an arduino bluetooth capabilities. One such chip is the DSD TECH HM-19 Bluetooth 5.0 BLE Module with CC2640R2F Chip for Arduino and DI. Shown in **Figure 16**, this chip costs only \$10 and would give any arduino bluetooth 5.0 functionality. Since the arduino mega we are using at the heart of the project doesn't have onboard bluetooth, this would be a great and cost effective way to add that functionality. As discussed above the use of a chip like this would mean we could add a remote control functionality to the egoat which would be a huge plus in terms of our egoats feature set. At the very basic use case for bluetooth in our egoat, a bluetooth chip like this would be a great way to implement a kill switch. Bluetooth will definitely be on the table of considerations for our project.



**Figure 16: DSD TECH HM-19 Bluetooth 5.0 BLE Module with CC2640R2F Chip for Arduino and DIY**

#### **Advantages**

- Very cheap (<\$20) whether being bought as a separate chip or an arduino with one integrated already
- Low power consumption
- Easy installation and paring
- Many DIY guides and walkthroughs of how to use bluetooth with an arduino

## **LoRa**

The other communication systems have bits and pieces of what we need, but none have the entire package. Currently, we are looking for a long range protocol with low power consumption and low data rate. After researching for a style with these conditions, we found LoRa. LoRa is a communication system, **Figure 17**, that is low power, low data rate, long range protocol, capable of keeping a connection over miles with very little power. There are a few different operating frequencies that we can use. They are radio frequency bands in North America are 433 MHz and 915 MHz.

It has been demonstrated that it is possible to build a versatile, long-range network on top of LoRa called LoRaWAN, which allows several LoRa devices to connect to a single gateway, which is another device designed to handle multiple signals. There are many different communication techniques that can be built using LoRaWAN, such as connecting and transmitting data to a web server. It eliminates the need for mobile or wi-fi connections by building a robust, well connected network of LoRa devices. Such a system could also be implemented for our project and its base station and potentially other eGOAT units to form as low-power, long-range network that allows extremely versatile communications and coordination. The figure below illustrates how such a network might be constructed.

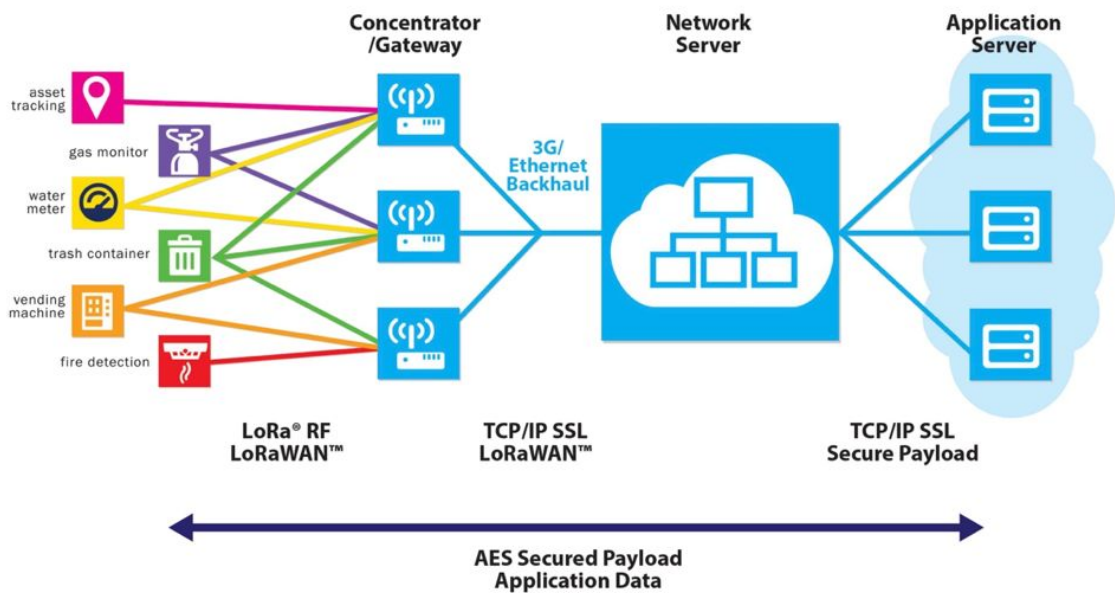

Figure 17: LoraWAN Web

### Disadvantages

- Not very common, requires specialized module and interfacing

- Low data rate (<50 Kbps)
- High bandwidth variance relative to max data rate depending on conditions

### **3.1.8 GPS Tracking**

The whole purpose of the GPS tracking of our device is to locate it. We will be implementing a beacon on a separate power supply. Beacons can be carried out through a variety of technologies and are used in multiple areas of industry to track and locate remote assets. They are most commonly seen in vehicle tracking, navigation, and pet or child location tracking.

#### **Globalstar Satellite Transmitter**

A good example to break down to understand how satellite tracking works is a Personal Locator Beacon (PLB). PLB are most commonly used by hikers and anyone exploring the outdoors. A PLB works by sending out signals which are then picked up by satellites. The satellites are used by national help agencies who can use the signals to determine the location of the device. The PLB uses two signals: one at 406 MHz and a second at 121.5 MHz. The higher frequency signal is used to determine location within 5 km while the other can determine the location within 500 m. The advantages of using a PLB is that it requires no internet connectivity and is effective in most areas and environments. However, a strong battery is needed to output the signals.

Now that we know how satellite transmission works, we can look at a more suitable option for our project. The Globalstar Satellite Transmitter only requires 50 mA of current and 3.3 V input to power it up. The device has a sleep mode to conserve power and can be woken up with a simple interrupt. The benefits of using this type of GPS technology is that there is no limit range. On the other hand, this service requests a subscription which will increase life-time and operating cost of using their satellite.

#### **LoRa Shield**

The LoRa communication system described earlier is what best fits our project. Therefore we will discuss the LoRa Shield device. This device is specifically meant for arduino. It's compatibility will make the application the easiest. The Shield allows the user to send data and reach extremely long ranges at low

data-rates. It also provides ultra-long range spread spectrum communication and high interference immunity whilst minimizing current consumption.

### **3.1.9 Fencing**

Another requirement for our project is to provide a backup kill system aside from the remote kill switch. In order to achieve this, we will consider a few of the options down below. The eGOAT must be able to identify its boundaries and be able to stick to them for both safety and efficiency. Most autonomous lawn mowers use invisible fences.

#### **GPS Fencing**

GPS fencing, also known as geofencing, is a virtual perimeter for a real world geographical area. A geofence can be set around boundaries of an area or a simple radius from a center point. The activity of crossing the edge could trigger an alert to the device's user as well as messaging to the geo-fence operator. This info, which could contain the location of the device, could be sent via our LoRa Shield.

#### **Invisible Fencing**

The invisible fence is a common technology that is used in both autonomous grass cutters and actually fencing dogs too. The fence is invisible to the eye because the key features of how the fence works are actually underground. A wire is placed underground and loops around the perimeter you want to make the boundary. Another good aid that can be seen in the picture is that if two wires are placed next to each other they actually cancel out each other signal so that the mower still know it can go over that area if it wants to avoid a certain spot.

### **3.1.10 Close Collision Sensor**

A bumper sensor is a simple type of close collision sensor that works by completing a circuit connection when it bumps into something. After the circuit is complete it will send a signal to the processor letting it know it has made contact with some object in front of it. The benefits of a bumper are that is a simple circuit making it very reliable. One negative of this sensor means that is has to have contact and actually hit something though for it to operate, which could possibly

damage some other portion of the eGOAT. This negative would be mostly negligible because the operating speed of the eGOAT would be at max speed 2 MPH. A bumper sensor sensor would be equipped to the front of the eGOAT and would be useful when the eGOAT is trying to cut around structure and due to some calculation error actually hits it letting the eGOAT know it has gotten to close.

### **3.1.11 Relays**

A relay will be utilized to isolate any power to the motors and components so that when a shut off is required at anytime the relay will sever power from the components the system needs to isolate. The relay will be controlled by the ESP32 microcontroller and needs to be powered and controlled through a data line. A relay uses a coil that when a voltage is applied the magnetic fields that arise from the current attract the contact that opens the circuit connected to it. It acts as a switch to open any circuit thus stopping the operation. The relay we will be using is a 1 channel relay:SRD-DC03V-SL-C. It is a 30V/10A DC relay has a response time of less than 20 milliseconds. This relay will be paired with a development board that will be external of the printed circuit board. The relay board cost \$2.60 each and fit the ratings needed to isolate the motors from the battery.

### **3.1.12 Motor Control**

In order for the robot to accomplish the required task, motion is required. Motors would therefore enable the robot to move around the solar farm and choose its path based off of inputs from the LiDar. Another function that motors play in this project is to provide motion to the sensor, this was chosen as a viable approach due to the fact that motors are relatively low cost components (comparing with the cost of sensors) and using it to provide one sensor the ability to capture data that would otherwise require multiple sensors to accomplish the same, is of advantage. The aspects taken into consideration regarding motors is described in sections to follow. With the LiDar placed properly on the robot it should be able to view the entire field and create a grid system that will allow it to move about and mow properly.

There are a variety of advantages and disadvantages that come from using electric motors. Electric motors have a much lower initial cost than a standard

engine, and because they have much fewer moving parts, they typically have a larger lifespan. They are also much more efficient than a standard engine. Another advantage is that they can be remotely powered on or off. Disadvantages include the fact that to provide the same horsepower rating, an electric motor would have to be much larger than a standard engine, making them far less portable. In places where power supply is limited, long line extensions can become costly.

In the scope of the E-GOAT project, electric motors will be used to drive the wheels on the robot, as well as the electric string trimmers.

## **DC Motors**

For the robot to be able to move around the solar farm and develop a proper path, standard D.C motors were chosen for this project. A DC motor is any of a class of rotary electrical machines that converts direct current electrical energy into mechanical energy. The most common types rely on the forces produced by magnetic fields. Nearly all types of DC motors have some internal mechanism, either electromechanical or electronic, to periodically change the direction of current flow in part of the motor. The motor selection takes into consideration the cost, speed and power consumption. From the design method chosen it was concluded that three motors are required, where two would serve the function of driving the robot around the garden and a further motor required to move the blades that cut the grass. A motor driver would be required in order to power these motors and for control functions.

The second method for controlling DC motors is through a motor controller. This is the more expensive way to control DC motors as most high current motor controllers start at about \$100 and go up from there, however, the use of a motor controller allows for more precise control of the current that is supplied to the motors which translates to accurate speed control. Using a motor controller is ideal for use with automated vehicles since the vehicle does not operate at high speeds and the vehicle needs to stop for objects and smoothly start up again. If the automated vehicle can slowly speed up from a stopped position, then the sensors and digital compass would be able to function more accurately and keep the vehicle on a preset track. For these reasons a motor controller is worth the extra cost in building an automated vehicle to ensure navigational accuracy. The lawn mower chassis was driven by two wheelchair motors that operate at 24 volts. These motors require between 20 and 25 amps of continuous current to run at full speed. A motor controller that can interpret commands given from a microcontroller is ideal so that steering and navigation of the automated vehicle are achieved with ease. Although the DC motors does not continually consume 25 amps due to the motors being operated at lower RPMs, a motor controller that

can sustain these high currents is ideal as to not cook the circuitry if such high currents are needed.

## H-Bridge Motor

An H bridge is an electronic circuit that switches the polarity of a voltage applied to a load. These circuits are often used in robotics and other applications to allow DC motors to run forwards or backwards. Most DC-to-AC converters (power inverters), most AC/AC converters, the DC-to-DC push-pull converter, most motor controllers, and many other kinds of power electronics use H bridges. In particular, a bipolar stepper motor is almost invariably driven by a motor controller containing two H bridges shown in **Figure 18**. This method is the best way to implement a turn. This is done by switching the polarity of the voltage supplied causing the circuit to change torque direction. A diagram of the H-Bridge is shown below to explain this idea. Most H-Bridge circuits contain protective diodes that will prevent damage to the PCB.

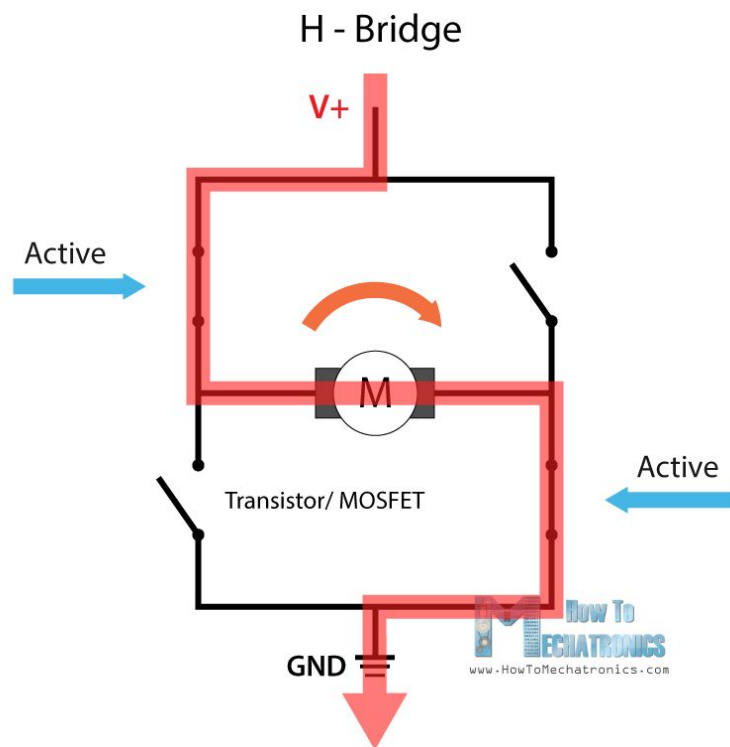

Figure 18: H-Bridge Motor Diagram

## Speed Control

Controlling the speed of the device is very important. One of the obvious things that our system will benefit from is using this to turn. Speed control can be very crucial to implement a perfect turn. Speed can also be increased when no obstacles are in the way to decrease the total time required to cut the 10 foot by 50 foot area under the solar panel. The most common way to control speed is using a PWM circuit. This Pulse Width Modulation input to the motor will provide different speed by finding the average voltage. The average voltage is directly related to the duty cycle of the signal. **Figure 19** below can explain this idea more clearly.

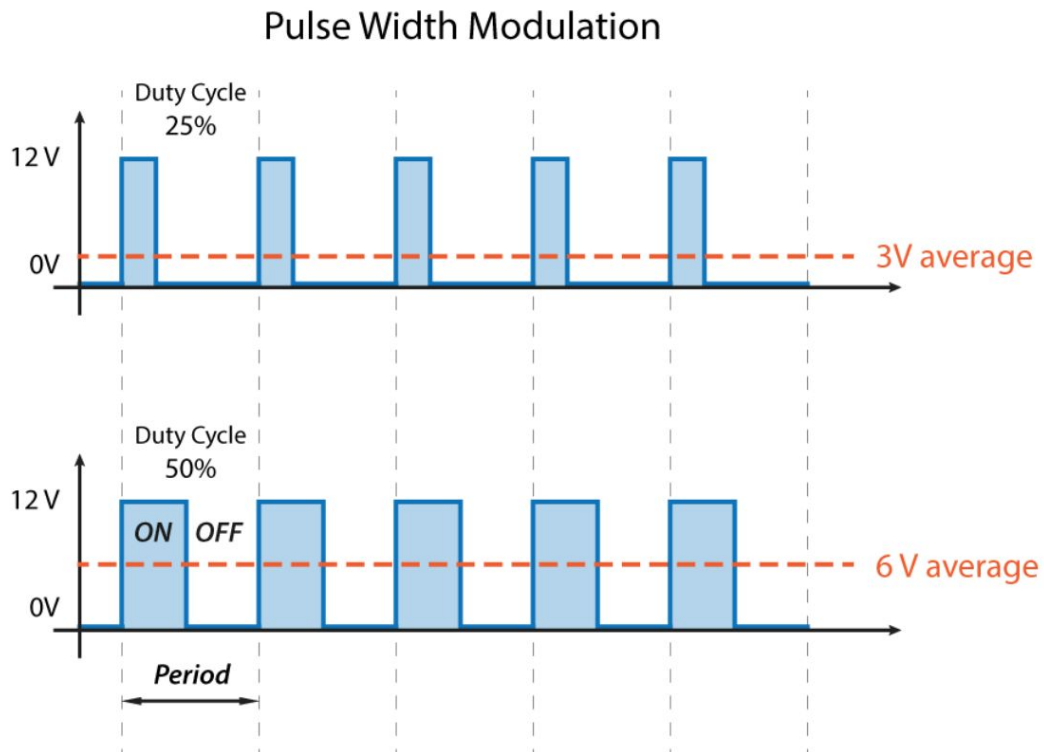

Figure 19: PWM Speed Control

## Breaking

One thing to consider with our device is breaking. When researching and pondering the idea of stopping our device, it became apparent that simply cutting the power supply from the motor would not be sufficient. This is due to the fact that once the power is cut, the momentum from the last input into the motor will dictate how long it takes our system to come to a complete stop. In order to get



around this, common motor controllers carry out a mechanism that applies an equal voltage to both sides. There is a use-case that should be avoided at all times; that is, turning on one side of the H-bridge, which will create an almost direct path from the voltage supply to ground. This will short out your circuit and damage components, batteries, anything in the circuit. There's only one side shown below as an example, but the same would hold true for the other side, and if all four were turned on at once. So, there're a few more hidden details which need to be accounted for when designing an H-bridge motor driver, but that's the general concept, and it's how most motor drivers work. As you can see, digital logic, timing functions, and safeguards need to be implemented to control the motor driver, but the hardware can be interfaced fairly easily to a microcontroller.

### **3.1.13 Blade Motor Controller**

For our project, we needed some means by which to electronically control our blade motor, as one of our requirements is that the system must have a 'kill switch' to deactivate itself should it get out of range, go off-path, or present some other danger to people or the environment. Since the blade motor was originally activated via a mechanical pull chain (like any typical lawn mower), this device had to be completely novel to the design. Moreover, we needed something that could take in a low current digital signal (0-5V) and output a high current, higher voltage, DC signal. As a result, we decided to use a motor controller to achieve these goals.

### **3.1.14 Mechanical Overview**

Major components of a lawn mower typically include the housing and wheels, carburetor, air filter, spark plug, lubrication system, blades or cutting implements, deck, drive belt, engine, handles and levers, bearings, discharge chutes, covers, rear axle, brackets, and rods.

The housing and wheels include the chassis or framework that is typically comprised of steel or resin based plastics that have high vibration and heat resistant properties. This housing then sits on a form of axle-connected wheels and covers the moving parts of the lawn mower. Since this project will be electric powered based and not gas powered like typical lawn mowers with an engine, details on the carburetor, air filter, spark plug, drive belt, and the engine will be disregarded as they are not relevant.

Types of cutting mechanisms and blades were also researched but we found out that the cutters must be made of nylon string so the other mechanisms searched have been disregarded.

Discharge chutes seem to be a prominent subject that popped up and are to help direct the direction of the cut debris. The cover serves the same purpose as a discharge chute, which is to keep the blades or cutters from being exposed and to help control the direction flying debris goes. The rear axle, brackets, and rods help secure the shift controls. The handlebar is for the operator to be able to control the direction of the lawnmower, and depending on the type, it helps control the direction, brakes, and power given to the mower through the clutch. From our current design which will be found further in the report, both the handle and wheel supports were influenced from our research.

### **3.1.14.1 Torque Vs. Speed**

Torque is the moment of a force, or the tendency of a force to rotate the body to which it is applied. When looking at torque in regards to a motor, it is essentially how much rotating force the motor has, and is measured in pounds per inch. In a vehicle, you can consider it the force that the vehicle has to turn an axle. The more torque a vehicle has, the better its acceleration is. Torque is also a factor that helps a vehicle drive through mud or up steep hills.

Speed is how fast an object will go. In a motor, it is the rate the motor is spinning at, or RPM. Speed and torque are typically inversely related. Determining if a larger speed or torque is required is a crucial planning step in a project. Putting a motor through a job where it lacks the necessary torque requirement could burn out and ruin the motor. If large amounts of friction are present in a certain driving condition, a larger torque would be desired. However, if the friction is relatively low, speed can be focused more on. The power rating of a motor is:

$$\text{Power} = \text{Speed} * \text{Torque}.$$

So, to maintain the same power, to increase the torque, the speed decreases. This shows the inverse relationship between the two factors. Different motors will give different torque or speed outputs, but through the use of gear systems, this output can be significantly changed.

### **3.1.14.2 Gear Ratio/Gear Systems**

Gears are almost always used in things with spinning parts, such as in a car engine or wall clock. Gears are used for multiple reasons: to reverse a rotation direction, to increase or decrease the speed or torque of the rotation, to change which plane the rotation is occurring, or to ensure that rotation stays synchronized. When two gears are attached to each other on different axles, the gears rotation will be in opposite directions. In some situations, it would be necessary to place another gear in between the two, to make sure the outside gears rotate in the same direction. Gear ratios are dependent on the number of teeth on the gears involved. In a simple gear system, a driving gear with 60 teeth connected to a gear with 30 teeth gives a 2:1 gear ratio. However, there are also more complex gear systems called gear trains. In a gear train, different sized gears are placed on the same axle to effect the gear ratio. If gear one is touching another gear half its size, the small gear will spin twice as fast. Now, if that small gear is on the same axle as another gear the size of gear one, and that gear then touches another small gear, the rpm is now four times as fast as the first gear. This gear train can continue to double the rpm with every addition. Conical gears have angled edges, which when connected together, can change the axis of rotation. These gears can take a rotation in the XY plane and convert it into rotation in the YZ plane. In a simple gear system, an odd amount of gears will have the outside gears spinning the same direction, while an even number of gears will result in the gears spinning in opposite directions. However, in general, every gear in a simple gear system needs to have an axle through it, which can be inconvenient. To alleviate this, a gear chain can be used.

A gear chain is a way to attach two gears that don't touch and ensure that they rotate in the same direction. Chains give the ability to create a system that can spread far apart, but still use few parts. They are lightweight and very efficient, but are only used when large changes in gear ratio isn't necessary.

In a gear system containing two gears, if the gear with the input shaft on it is larger than the output gear, this system is providing more speed. The larger the difference in size between the gears, the more speed there will be. In contrast, if the input gear is smaller than the output gear, this system increases torque. It is important to know the limitations of your motor, as creating a system with too much torque could be too hard on the motor and keep it from spinning.

### **3.1.14.3 Electric motor Vs. Gas Engine**

When comparing an electric motor to a gas engine, one must take into account the desired application for each. In the case of an automated lawn mower, the application demands a motor with sufficient torque that can be delivered to the wheels and a degree of control to manage fine movements over a small range.

Perhaps the most important, the torque that the engine or motor delivers, and is used by the system, is a good indication of how effective the mechanism as the drive system for the wheels of the device. Generally, electric motors produce more torque at the operational speeds we desire for our device, meaning that for less energy, electric motors provide more power and speed to be used effectively.

In general, gas engines provide more raw power, capable of moving large pieces of machinery with relative ease. However, when it comes to fine control in a limited setting, gas engines lose to electric motors, due to the natural difficulty of capturing controlled explosions versus evenly applying electricity to a magnet. At lower speeds, gas engines cannot deliver accurate movements due to all the moving parts and the extreme amount of heat that is generated. Electric motors are much more suited to these situations, because even though they lack a high amount of pure power at high speeds, they make up for this with their precise and accurate motion at low speeds.

### **3.1.14.4 Tire and Tread**

When it comes to categorizing the important aspects of the locomotion system, selecting the correct tire with an adequate tread ranks relatively high. If the tire treads do not meet the environmental requirements for the system, the mower could become immobilized or thrown off-track, resulting in very poor cutting efficiency or necessitating a rescue from the field. Therefore, in order to prevent such unfortunate occurrences, special attention has been paid to the tires' radius and tread depth.

Ideally, the design should aim to maximize the radius of each tire, because this would lower the chances of the mower becoming stuck in small holes or ruts that may litter the terrain. However, due to the size constraints of the project and geometrical considerations from the relative placements of the cutting instruments, the maximum size of each of the four wheels cannot exceed twelve inches in diameter. Luckily the intended terrain of the mower (mainly flat grassy fields) does not require such extreme measures, meaning a tire diameter of merely six inches will suffice. Although the size of the tires has been scaled down to account for this, studded tires could be implemented in order to increase effective traction over potentially uneven or unreliable terrain, a precaution commonly taken by automobile drivers.

The tread depth of the tires is also an important factor that helps determine the acceleration of the mower in the slick terrain of a grassy field. For automobiles in the United States, the standard tread depth is 10/32", with off-road and winter tires having a deeper depth. A tire tread's effective traction

increases with a deeper tread depth, allowing the tire to maximize the contact surface area of the tread with the ground and dig into uneven terrain. However, a tread depth that is too deep could tend towards tire instability, so careful consideration should be lent to the tread depth in order to maintain an adequate balance of high traction and high stability, generally not exceeding 11/32”.

### **3.1.14.5 Motor String Trimmer**

String trimmers are a common lawn care tool most often used as a complement to lawn mowers. Its ability to effectively cut grass is based off of the principle of centrifugal force, meaning the faster the head of the trimmer spins, the stiffer the string becomes. String trimmers provide the ability to level areas of grass which may be in tight spaces such as along fences, trees, and mailbox posts. In addition to their compact nature, string trimmers can also cut grass while avoiding damage to surrounding obstacles.

For the purpose of this project, an off-the-shelf trimmer is being considered as the cutting mechanism due to the specifications being readily available and easily comparable to other models. Rotations per minute, battery life, swath distance, string diameter, and cost are all variables that must be compared when deciding which model to incorporate into the grass cutter robot design.

In order to cut the grass in a timely fashion, it may be necessary to have two trimmer heads on the robot rather than just one. This will limit the team in what model can be chosen due to a restricted budget. Additionally, battery life must be extended for the scope of this project. Possible methods to increase battery life could be to add additional batteries to hold longer charges or replace the battery with a larger one. While the former could add a multitude of additional costs, the latter may pose an electrical failure if the battery is incompatible with the trimmer head.

## **3.2 Part Selection**

This section of the report will go into detail about each component and compare technologies. This section will list the exact components that we use in our system.

### **3.2.1 Switching Regulator**

LM2596DSADJR4G

The voltage regulator we chose is the LM2596. The LM2596 regulator is monolithic integrated circuit ideally suited for easy and convenient design of a step-down switching regulator (buck converter). It is capable of driving a 3.0 A load with excellent line and load regulation. This device is available in adjustable output version and it is internally compensated to minimize the number of external components to simplify the power supply design. Since LM2596 converter, **Figure 20**, is a switch-mode power supply, its efficiency is significantly higher in comparison with popular three-terminal linear regulators, especially with higher input voltages.

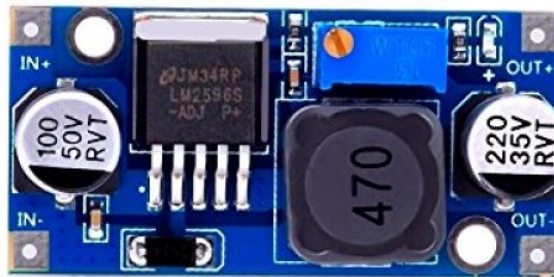

Figure 20: LM2596S Chip

### LM2596SX-5.0/NOPB

The LM2596 series of regulators are monolithic integrated circuits that provide all the active functions for a step-down (buck) switching regulator, capable of driving a 3-A load with excellent line and load regulation. These devices are available in fixed output voltages of 3.3 V, 5 V, 12 V, and an adjustable output version. The main difference between this regulator and the one above is that this one has the fixed outputs at common voltages needed.

## **3.2.2 Battery**

Batteries are used everyday, and are used to store energy for future uses. They produce energy by way of a chemical reaction when two unlike materials, a positive and negative component, usually plates, are immersed within an electrolyte solution.

### **3.2.2.1 Nickel Cadmium**

Ni-Cd batteries have the best hold voltage and staying charged, this means that when the battery is not in use the voltage stays at a constant level, or has a very

slight drain on its charge. Unfortunately the memory effect occurs easily in Ni-Cd cells, which occurs when the battery is recharged while not fully depleted. This damages the cell and reduces the future capacity of the battery. They are also good for supplying their full rated voltage at high discharge rates. **Figure 21** shows the components inside a Ni-Cd battery.

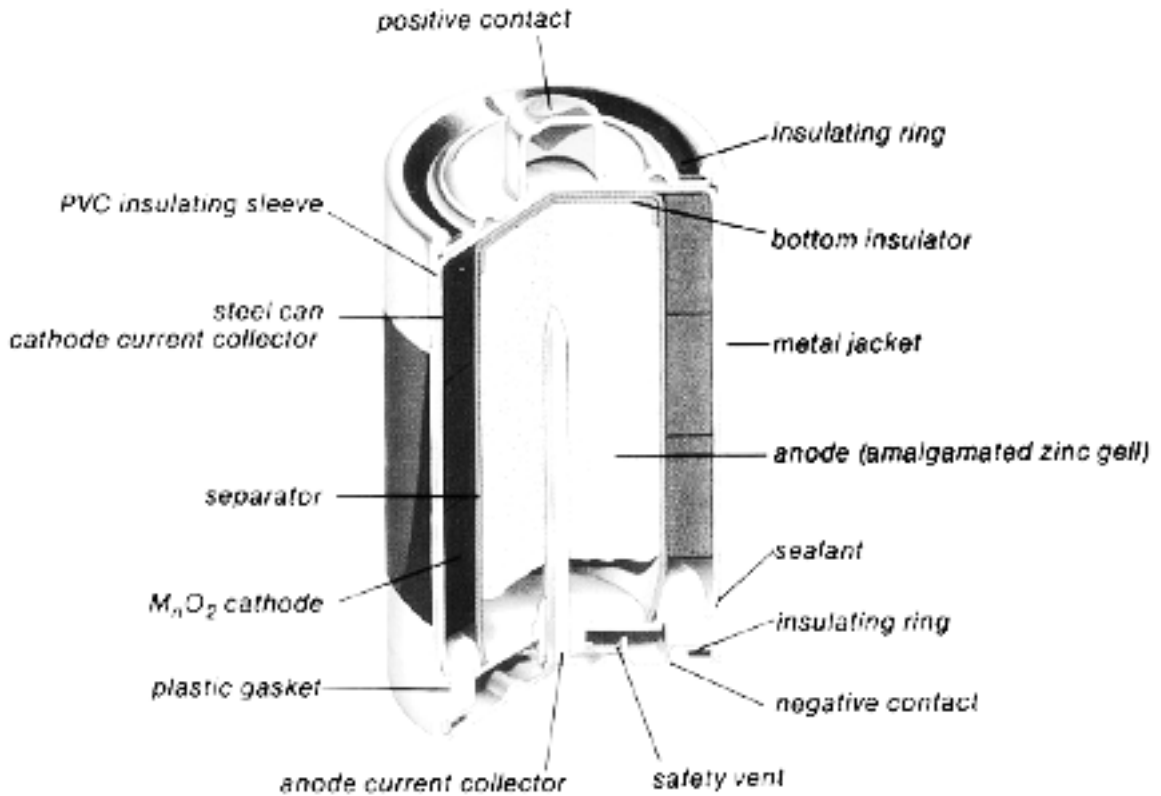

**Figure 21: Ni-Cd composition**

### 3.2.2.2 Lithium-Ion

Li-ion batteries have the lowest risk associated with their use do to them having low self-discharge and them having little to no memory effect, along with them having the highest energy density to weight ratio. Due to this, the batteries can be smaller and still have a high energy output. Li-ion batteries are mostly used in cellphones and other household appliances. **Figure 22** shows a basic understanding of how the Li-ion battery charges and discharges.

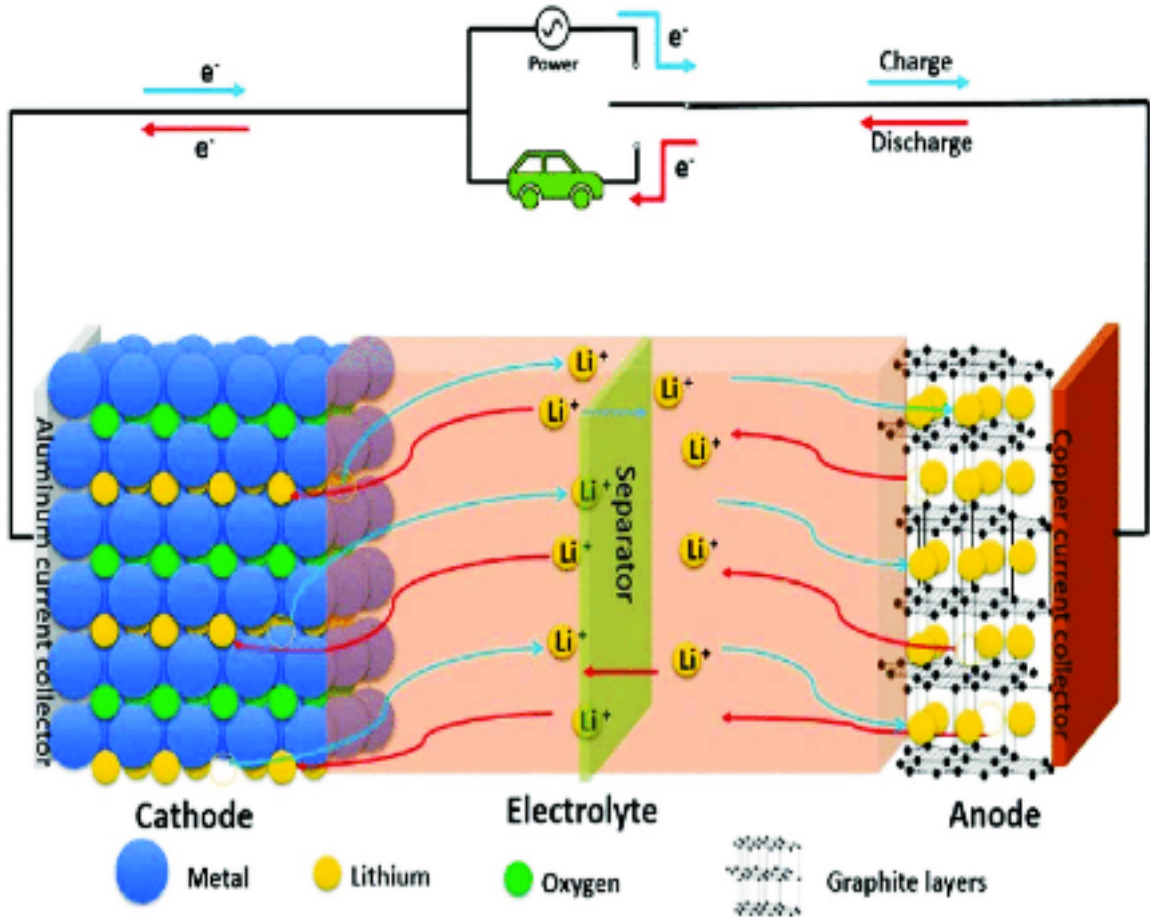

Figure 22: Lithium-Ion Schematic

### 3.2.2.3 Nickel-Metal Hydride

Ni-MH batteries have a high capacity and high energy density, as such similar sized batteries, one of Ni-MH and one of Ni-Cd. The Ni-MH will have about two to three times the capacity of the Ni-Cd battery. They are usually used in high drain devices and do not have to worry about the memory effect due to their chemistry composition. **Figure 23** shows the composition of a Ni-MH battery, inside and out.



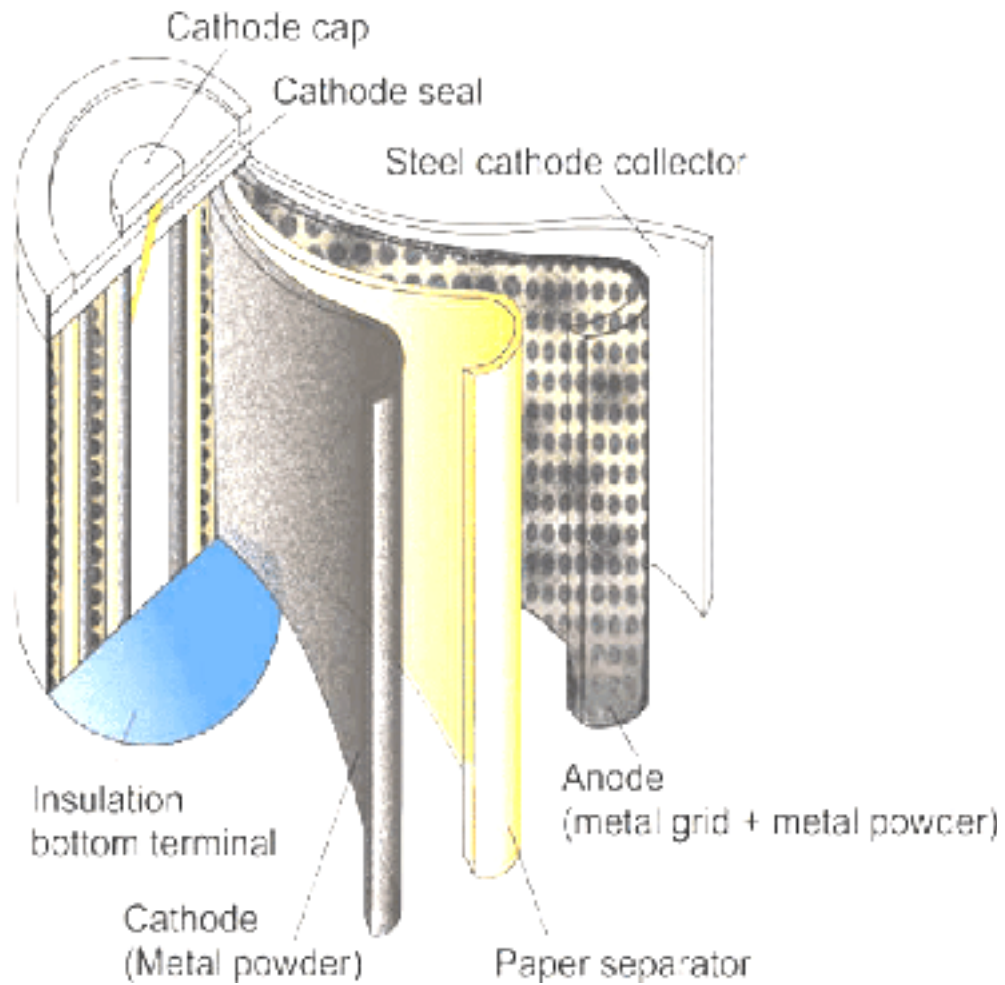

Figure 23: Ni-MH dissection

### 3.2.2.4 Lead-Acid

Lead-Acid batteries are used in heavy duty appliances or machines. They have a low energy to weight ratio but incredibly high power output and as such are used in devices that need high currents to operate, such as car starter motors and back up power supplies. **Figure 24** shows the chemical composition of a lead acid battery and the direction of the flow of energy as the battery depletes.

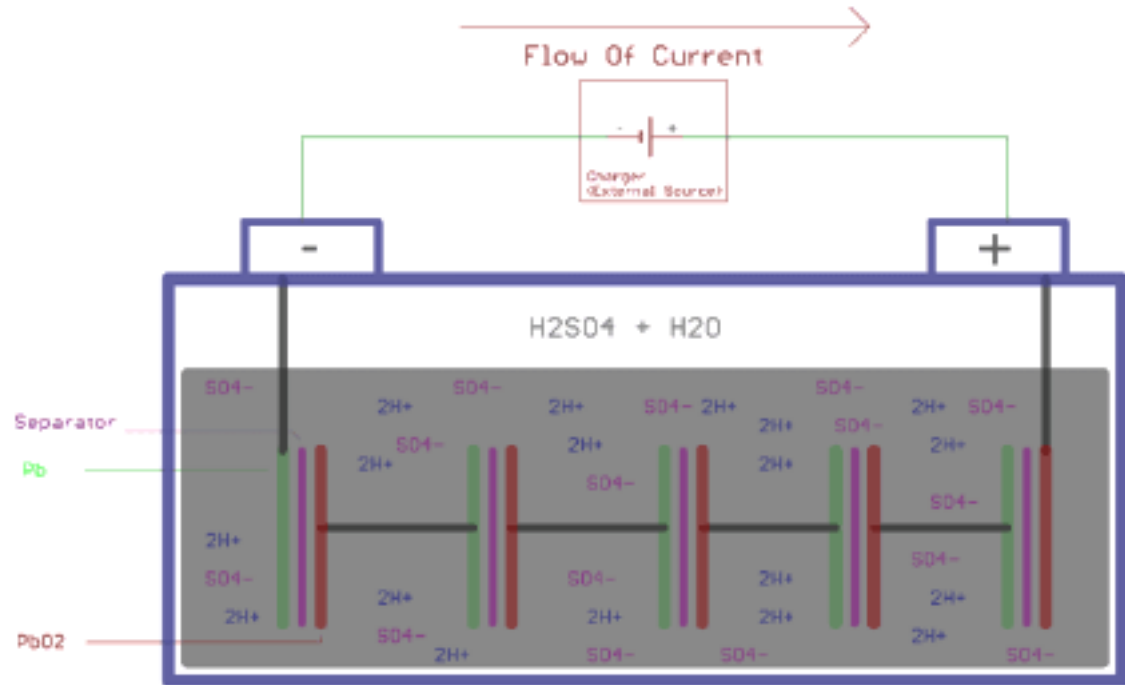

Figure 24: Lead-Acid Diagram

We will be using the secondary battery type within our system, due to the requirement specification stating that the battery we are to use needs to be rechargeable. The sub-type of secondary battery that shall be used for the electronic components will either be a Lithium-Ion or Nickel-Metal Hydride composed battery. For the Mechanical components, such as the motors and weed wackers, we shall be using a Lead-Acid battery.

### 3.2.3 Proximity Sensor

A big problem with mowing a lawn automatically is making sure that the mower stays within the bounds of the lawn, and we have implemented proximity sensors as part of our control system in order to solve these issues. We will be integrating two Sharp GP2Y0A21 Distance Sensors on the front end of the mower in order to help detect when the mower is approaching the walls of the boundary. This module will be powered by the microcontroller by a 5V source and will also be directly grounded to it. The microcontroller will take an input from the proximity sensors that will be an analog signal from 0-5V that corresponds to how far away the robot is from the wall. The proximity sensors begin to output a voltage when the robot gets within 100cm of the wall, so this is more than sufficient for our purposes. The proximity sensor acts as a resistor that allows a higher voltage to pass through when we are closer to the object. When the voltage hits a certain threshold, we will know that it is time to square the robot up with the wall and

perform a half turn in order to mow in the other direction. With these modules mounted on the front, the control system will be able to know when there's a wall in front of the robot as well as be able to detect any other obstacles that may lie in the way of the robot as a safety feature.

### 3.2.3.1 Ultrasonic Sensor

The first sensor we looked was the ultrasonic sensor, shown in **Figure 25**. Of the three sensors this is arguably the most popular of the bunch. This device shoots a high frequency sound wave and records the time it took for the signal to bounce back; distance can be calculated from a fixed velocity and the recorded time. This type of sensing is crucial for navigation and determining positioning, however an issue with this sensor is that it can be affected by high levels of volume from unwanted sources. The issue with this is that the EGOAT is being made for the outdoors, this could mean there could be other loud noises that would be out of our groups control to stop. If we used this sensor these outside noises could have a negative effect on the EGOATs navigation which could cause it to crash and not successfully complete its job. As a group we decided it was best not to use this kind of sensor because of this issue.

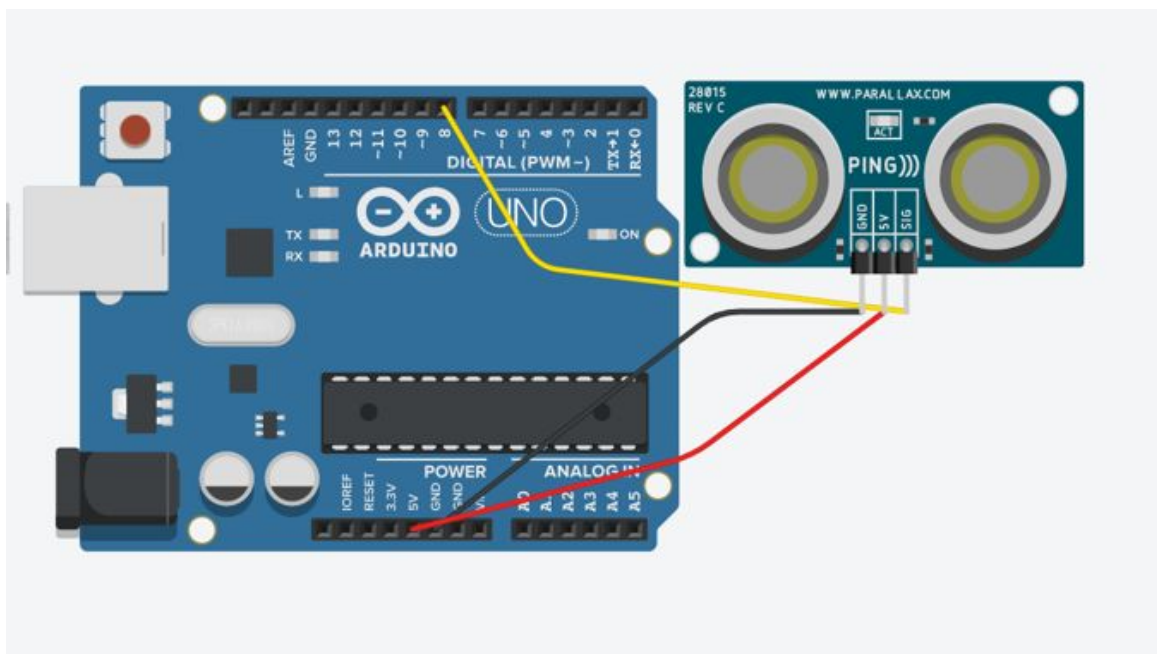

Figure 25: Example Ultrasonic Sensor with Arduino

### 3.2.3.2 Infrared Obstacle Avoidance Sensor

An Infrared Obstacle Avoidance Sensor has both a built in IR transmitter, IR receiver and a potentiometer. The IR transmitter will send an infrared signal and this signal would reflect off of some surface and bounce back into the IR receiver, shown in **Figure 26** below. The potentiometer will be used to adjust the detection range to our liking. The basic idea of an Infrared Obstacle Avoidance Sensor is that if there is no obstacle, the emitted IR signal from the IR transmitter will weaken and disappear with the distance thus no IR ray will bounce back. In the case of an object in the way this will act as the surface that the IR signal will bounce off of to come back in the IR receiver. This sensor has good stable response whether in the dark or in ambient light. The issue this kind of sensor can have however is if the surface the IR signal is hitting is not reflective. If an IR signal hit a black surface, the color black is not reflective, thus the IR signal would never make it back to the IR receiver so the object wouldn't be detected. We do not yet know the design of the course the EGOAT will go through, thus we do not know if this will be a detriment or not. If the obstacles it needs to avoid are not black then this sensor would work in practice, however, if they are black then the EGOAT would essentially be blind to this obstacles which we cannot allow. The group has decided to not use this sensor because we do not have enough details about the course the EGOAT will be put through.

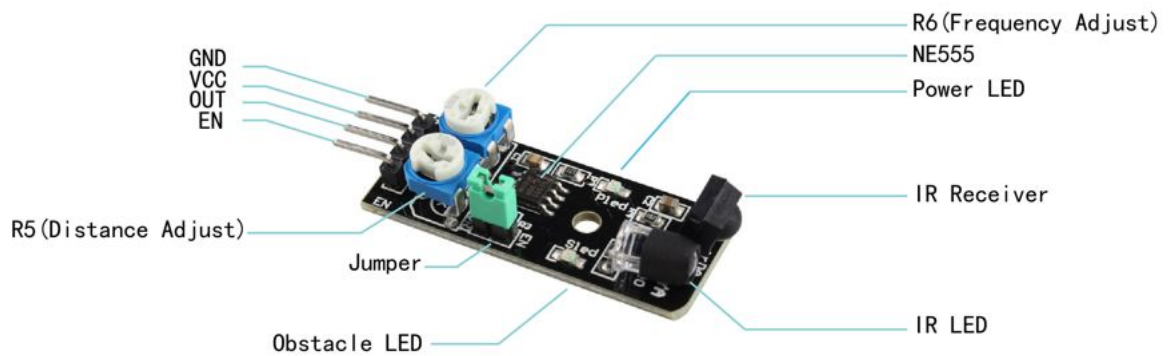

Figure 26: Infrared Obstacle Avoidance Sensor with it's components detailed

### 3.2.3.3 LiDar

LiDar means Light imaging, Detection and Ranging. It uses focused light and sensors to detect reflectivity and range. Lidar can be found in most self-driving cars in this day and age. Lidar sends a beam of focused light that hits an object then this beam is reflected back into the lidar. The reflectivity can be determined by the beams intensity while the distance is determined by the beams travel time. Lidar for a self driving car is utilized along with an orientation sensor. It is far better suited for outdoors compared to the ultrasonic sensor and it doesn't have

the drawback of certain surfaces not being able to reflect back it's needed signal like the Infrared Obstacle Avoidance Sensor. The issue with the Lidar would be cost. It is far more expensive than both the ultrasonic sensor and Infrared Obstacle Avoidance Sensor, however because of our funding we will be able to afford a decent Lidar system so the group decided to go with a Lidar. When it comes to LiDar however we have two options we could use, one option is the one directional LiDar sensor like the TF Mini LiDar Laser Range Sensor or a full 360° LiDar such as a RPLIDAR A1M8 - 360 Degree Laser Scanner. Both these sensors can be found at dfrobot which is a website which specializes in selling quality arduino parts and sensors which is good for the group since we are using an arduino microcontroller.

### **3.2.3.4 TF Mini LiDar Laser Range Sensor**

The TF Mini LiDar Laser Range Sensor from dfrobot is a low cost stationary LiDar device that costs \$39.90. The reason it comes at such a low cost is because it uses a focused IR LED rather than a laser. It has a range that goes as little as thirty centimeters up to twelve meters (about one to four feet). It has an internal processor that supports serial input/output which will be good for testing and debugging when we actually implement into the EGOAT. It samples at a maximum rate of 100Hz which is great for the EGOAT as it needs to constantly be monitoring its surroundings to ensure it doesn't crash into an objects. Figure 6 shows the pin configuration of the TF Mini LiDar Laser Range Sensor. The VCC pin requires 4.5V - 6V to work meaning it will work well with a 5V which suitable for the arduino microcontroller we have chosen to use. The data sheet for the TF Mini Lidar Laser Range Sensor shows that the Tx and Rx logic lines. This could prove to be an issue as putting a 3.3V output to a 5V input is safe but putting a 5V output to a 3.3V input isn't safe if the inputs aren't tolerant so we would use a logic converter to drop the voltage. Figure 7 shows an example of how the TF Mini LiDar Laser range Sensor would be interfaced with an arduino. To ensure the EGOAT doesn't crash we would need at least two of the TF Mini Lidar Laser Range Sensors, one on the front and one on the rear so that it can monitor the front and if there is something in the way or there is any need, the EGOAT can reverse and switch to using the TF Mini Lidar Laser Range Sensor on the back, shown in **Figures 27 and 28** below.

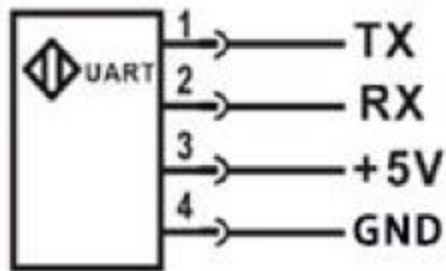

Figure 27: TF Mini LiDar Pin Configuration

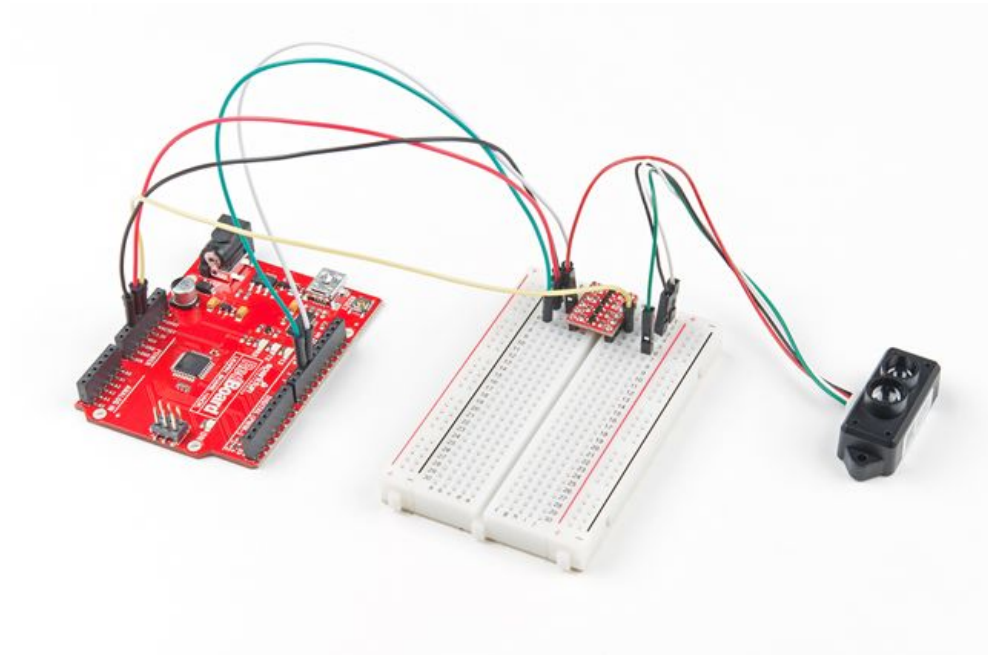

Figure 28: TF Mini LiDar hooked up to microcontroller w/ logic converter

### 3.2.3.5 RPLIDAR A1M8 - 360 Degree Laser Scanner

The other lidar sensor that can be used is the RPLIDAR A1M8 - 360 Degree Laser Scanner. The scanner costs \$99 but if we decided to use this sensor we wouldn't need to use two TF Mini Lidar's. The RPLIDAR A1M8, **Figure 29**, sports a 360 degrees omnidirectional LIDAR scanner and uses laser triangulation. Unlike the TF Mini Lidar which relies on IR the RP Lidar doesn't use IR at all. One worry with a 360 degree sensor was if it would be fast enough at scanning to ensure that while it's driving forward but scanning behind it, it wouldn't crash. This is something we wouldn't have to worry about with the RP Lidar however because it samples 8000 points per second at 10Hz. It has an internal wireless connection so no need for a slip ring and it has a minimum range of 30cm and a maximum detection range of 12m (40 feet). With the rate and distance this Lidar can scan the EGOAT would be more than prepared to maneuver around any

obstacles in its way. It would also help with detection in going right or left. If something was in front of the EGOAT and something was also to the EGOATs right, then with this sensor the EGOAT can know beforehand to go left in order to avoid all these obstacles because it would have already scanned its surrounding area. The VCC of the RPLIDAR is a 5V DC Logic power supply, and the VMOTO pin takes in a 5v DC motor power supply as well. Unlike the TF Mini the RPLIDAR would not need any sort of logic converter to hook up with the pins. Different rates of scanning and sampling can affect the scan speed and accuracy. The motor speed controls the scanning rate, and the controlling software controls the sample rate. Fewer scans at a slower speed would be more accurate but we may not necessarily need such levels of accuracy. The EGOAT will only care if something is in its way, so having a faster rate at a high scan rate may be better for the EGOAT. The lidar will come with its own software development kit for ease of programming as well as having its own driver, and library for arduino development that makes it easy to interface.

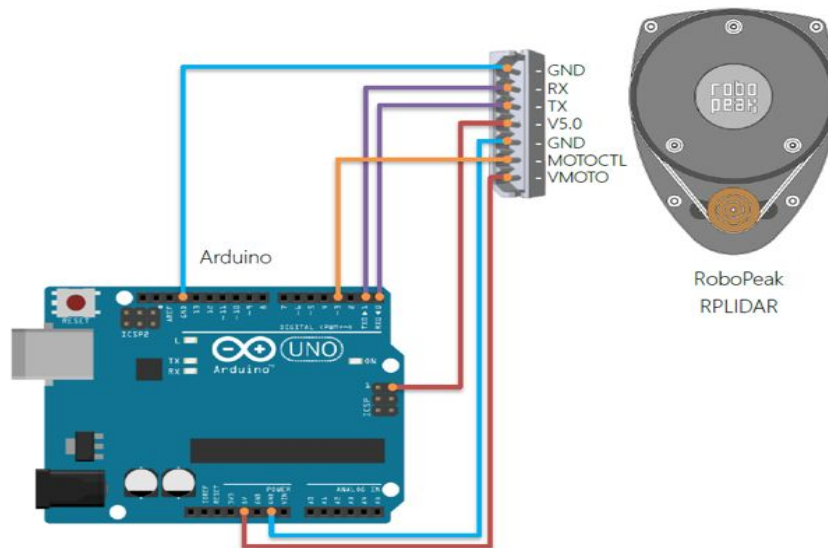

Figure 29: RPLIDAR w/ pin configuration interfaced with an Arduino

### 3.2.4 Limit Switches

Two limit switches will be added to the front of the lawnmower for increased safety. In case the proximity sensor would malfunction and not detect an obstacle, the lawnmower should still stop to avoid damage to it and to any obstacles or observers. For this project, Omron SS-01GLP limit switches were chosen because of their relatively low cost of about \$0.80 each. These switches



can be used on the external interrupt on the microcontroller, which will immediately stop the drive motors.

### **3.2.5 Microcontroller and Board**

When considering which microcontroller to use there are a lot of options we could look at but thus far the group is leaning towards using a microcontroller paired with the arduino family of boards. Aside from Arduino, we looked at texas instrument, raspberry pi, adafruit, and specific boards like the STM32F3 Discovery. We found that the raspberry pi, though a very useful and powerful board, has a lot of features we don't need so we decided against it. STM32 F3 Discovery is very programming heavy and doesn't have as much support as some of the other microcontroller boards we looked at. When comparing Arduino, to Texas Instrument and Adafruit, it came down to support and previous experience of the group. It was easier to find parts that support the arduino line of microcontrollers as it is a family of microcontroller boards that is far more well known than that of Adafruit. Then when comparing Arduino to Texas Instrument we found that Arduino is geared more towards individual projects and has is teeming with online support and tutorials for all kinds of sensors. This is the reason we chose to go with the arduino line of microcontrollers, because of the wide variety of online tutorials and support the arduino line receives. On top of all of that our groups computer engineer has experience with working with arduinos. For instance the TF Mini Lidar sensor and the RPLIDAR sensor that our group is looking to acquire has a library made for arduino's that make these sensors easier to interface with the arduinos.

Even though our group chose to go with the Arduino line of boards and their corresponding microcontrollers however we still need to look at all the different kinds of boards that Arduino offers and decide which would be best of our use case. When looking at the Arduino line of microcontrollers there is the Arduino uno, Arduino Mega 2560, Arduino Nano, Arduino MKR, Arduino Leonardo, Arduino Micro, as well as the Arduino Due and others. However the differences don't end there. For instance any one line of Arduinos can have different variations. Some have wifi, and headers while others do not. The different arduinos also vary widely in price, ranging from \$9.90 all the way up to \$83.90. When considering which Arduino to buy we need to think heavily about our budget and our needs but also what works best for what we need. We don't want to end up in a situation where we went for a cheaper Arduino to cut cost but then realize we should have gone with a different line that costs slightly more but gives us a feature that we could use. No matter the decision however compatibility when it comes to software won't be a huge factor as Arduino has its own designated integrated development environment that makes programming them easy as well as user friendly. The biggest factor here is features vs cost. It's



also worth noting that Arduino is open-source hardware so there are copies of their board designs that are entirely legal and could potentially be far cheaper than the official arduino boards.

### 3.2.5.1 Arduino Uno

The Arduino Uno, **Figure 30**, is the Arduinos most standard board. It is the most used and well documented board of the whole Arduino family with most online guides being based on it. The Arduino Uno is based on the ATmega328P microcontroller and has 14 digital input/output pins with six of them able to be used as PWM outputs. It also comes with six analog inputs, a 16 MHz clock speed, power jack, headers, and a reset button. It uses the Arduino software to be programmed and is very versatile. The Arduino Uno costs \$22.00. It has an operating voltage of 5V with an Input Voltage recommended between 7V - 12V. This would be a good board to use for our project, with the only real negative being the limited amount of input pins.

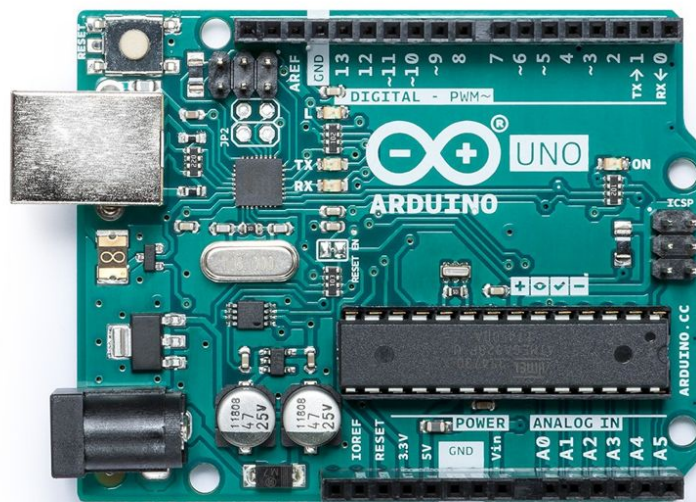

Figure 30: Arduino Uno

### 3.2.5.2 Arduino Nano

The Arduino Nano, **Figure 31**, is a small and compact but also a complete and breadboard-friendly board. Like all Arduino boards it is programmed using the Arduino Software IDE. Unlike other Arduino boards it lacks a DC power jack and uses a Mini-B USB cable rather than a standard one like most other models. It is based on the ATmega328P microcontroller and offers the same connectivity and specs that could be found on an UNO board. The previous years EGOAT project our group took home has two arduino nanos inside of it that we could reuse. This

could be troublesome however as the nano does not have headers so in order to reuse the 2 Arduino Nanos, we would need to desolder the nanos then resolder them again when we are ready. If something is done incorrectly we would again need to desolder and resolder. Acquiring a board with headers may be better for our group as it would be more plug and play than a board without headers such as the Nano. The Nano operates at 5V and it's recommended input voltage is between 7V - 12V. It is enough to power the Lidar sensors if we choose to go that route with sensors as well. It has a 16MHz clock speed, eight Analog In pins, 22 Digital I/O pins, six of which are PWM and has a power consumption of 19mA. An Arduino Nano costs \$22.00 but being that we already have the two from the prior project at our disposal we can save some money in reusing them. The limited number of pins on the Nano could be a cause of concern when using them and hence why two may be needed. It is also worth noting the Arduino Nano has many variations, such as the Arduino Nano 33 BLE Sense. This variation for instance includes bluetooth 5.0 and has many sensors already built in such as a 9 axis Inertial Measurement Unit as well as a pressure, light, color, gesture, temperature, and humidity. It even has a microphone. Though these are all neat features they may not be necessary features for the EGOAT and this Variation of the Nano board is \$29.

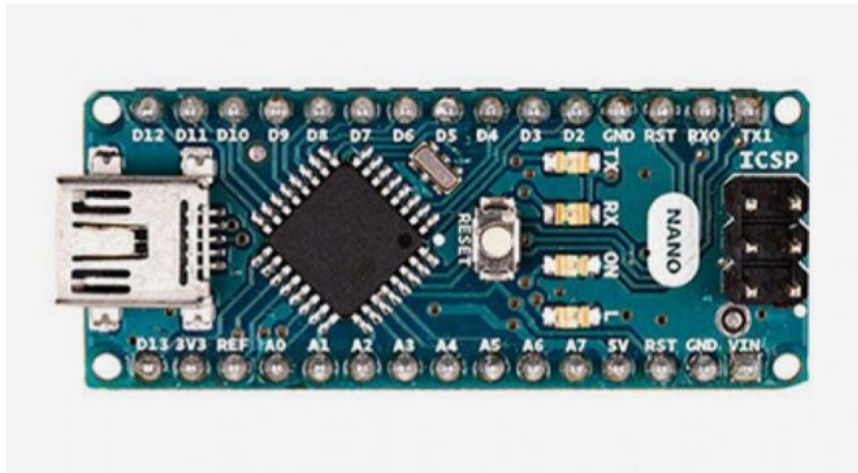

Figure 31: Arduino Nano

### **3.2.5.3 Arduino Leonardo**

The Arduino Leonardo is a microcontroller board based on the ATmega32u4 microcontroller. The Leonardo has 20 digital input/output pins with seven of them being able to be used as PWM outputs and 12 of them as an analog input. It has a 16MHz clock speed, power jack, headers (a variation of this board without headers is available however), and a reset button. It is very similar to the UNO

with the main difference being in the microcontroller itself. The ATmega32u4, when plugged to a computer, can be seen as a mouse and keyboard. This is because the ATmega32u4 microcontroller has a built-in USB communication therefore it doesn't need a secondary processor. It is worth noting however that it can still be seen as virtual serial and COM port. Much like the UNO it has an operating voltage of 5V with a recommended Input Voltage of 7V - 12V. It is programmed with the Arduino Software. The limited number pins could again potentially be a problem with this board.

### **3.2.5.4 Arduino Mega 2560**

The Arduino Mega 2560 Rev3, **Figure 32**, is the board that my group is most leaning towards. The Arduino Mega 2560 Rev3 is based on the ATmega2560 microcontroller. Like all other Arduino Boards, it is programmed using the Arduino Software. It has a total of 54 digital I/O pins, 15 of which can be used as PWM outputs and it has 16 analog input pins. This far exceeds the amount of I/O pins available on the Arduino UNO which has only 14 I/O pins available. It still has a 16MHz clock speed, power jack and a reset button. The Arduino Mega also has 13 built in LEDs which can come in handy for identifying the different states the different states the EGOAT can be in or be used for debugging purposes. The Arduino Mega does have a larger footprint than all the other boards we have taken a look at but it is still relatively small and it shouldn't be an issue fitting this board into the E GOAT. Compared to the Arduino Uno which only has 32Kb of Flash Memory the Arduino Mega 2560 has 256KB of flash memory. The Arduino Mega 2560 Rev3 is designed and built for more complex projects in mind. Arduino recommends this board for robotics projects. It includes headers unlike the Arduino Nanos which makes the Mega 2560 a better board for reusability as well. It can be easily unplugged and replugged and we wouldn't need multiple of them like the previous years EGOAT needed multiple Arduino Nanos. If we use one Arduino Mega 2560 then this would most likely be the only microcontroller board we need in the whole EGOAT.

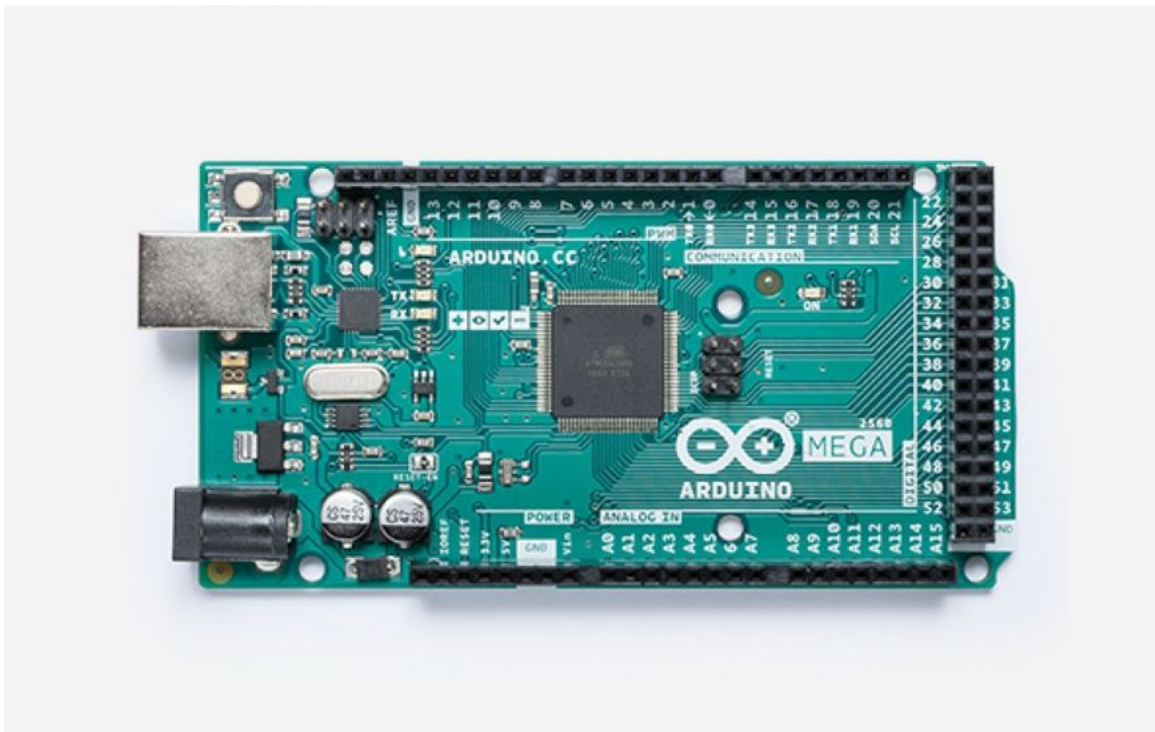

Figure 32: Arduino Mega 2560 Rev3

### **3.2.5.5 Arduino Due**

The Arduino Due microcontroller board is based on the Atmel SAM3X8E ARM Cortex-M3 CPU. It has 12 analog inputs, 54 digital input/output pins, and is geared for more powerful large scale projects. It is the first Arduino board based on a 32-bit ARM core microcontroller. It has 4 UARTs, 84MHz clock, and 2 Digital to Analog converters. This board runs at 3.3V unlike most other Arduino boards and that is a huge detriment for this board. If we were to use Lidar like the group is planning to then 3.3V wouldn't be enough just to power the TF Mini Lidar sensor 4.5V - 6V is required. The Arduino Due with headers costs \$38.50. A potential problem with this board is the ARM based CPU it uses. More research will have to be put into if an ARM based CPU could cause trouble with sensors or other components on a compatibility front.

### **3.2.6 Remote Signal Processing**

This section will consider individual components that can be used to transfer data through signals. This is again important to implement our remote kill switch and send data between the car and our receiver. The diagram below shows how the two remote processors will communicate with one another in order to switch off the power in case of an emergency. We chose to use two arduino chips for the simplicity of communication between them. The main purpose of this section is to compare and contrast select transmitters and receivers that will get the job done best.

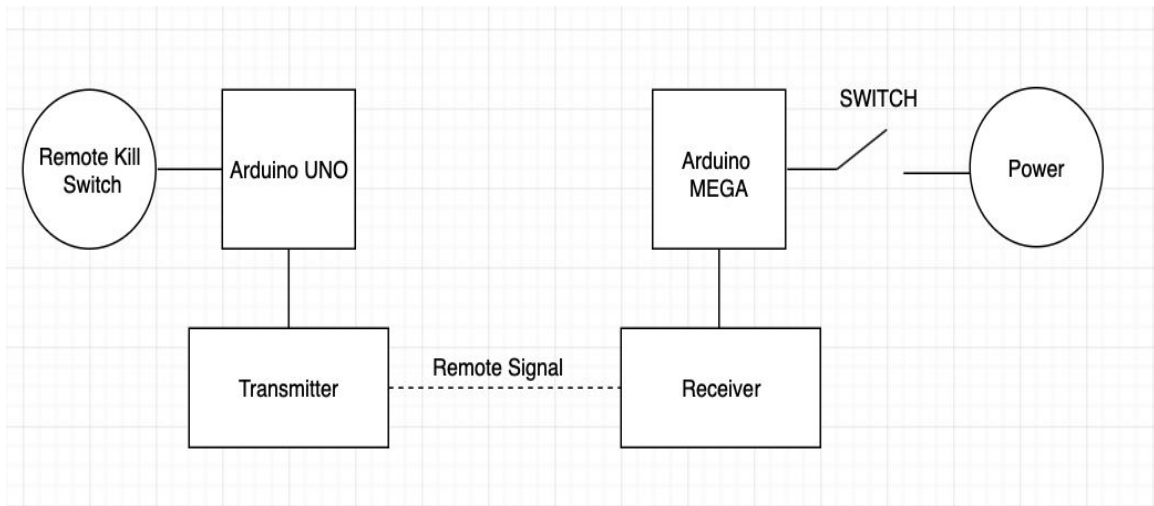

Figure 33: Transmitted Receiver Diagram

### 3.2.6.1 LoRa Shield

When looking through various products that will transmit the needed signal, we come to a conclusion that something simple, yet effect, would be best. Our system doesn't require anything complex. In other words, we needed to send one signal that was capable of interrupting our power supply. In addition, later on, we clarify that we plan to implement a remote device that can receive simple data to display on an interface. Our transmitter and receiver choice needed to fit these requirements. The figure below shows a LoRa shield.

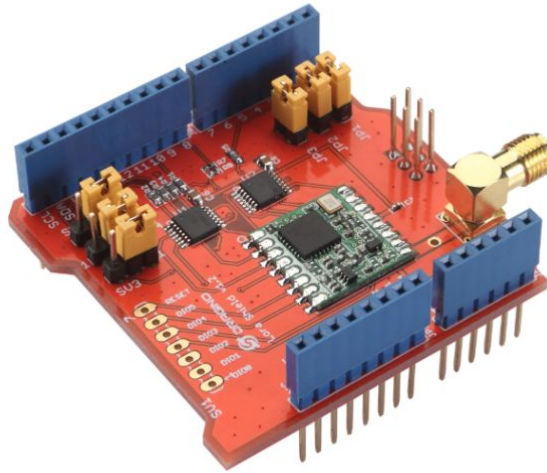

Figure 34: LoRa Shield-915

LoRa Shield is a long range transceiver on a Arduino shield form factor and based on Open source library. The Shield allows the user to send data and reach extremely long ranges at low data-rates. It provides ultra-long range spread spectrum communication and high interference immunity whilst minimising current consumption. LoRa Shield is based on Semtech SX1276/SX1278 chip, it targets professional wireless sensor network applications such as irrigation systems, smart metering, smart cities, smartphone detection, building automation, and so on. Using Hope RF's patented LoRa™ modulation technique the Dragino Shield featuring LoRa® technology can achieve a sensitivity of over -148dBm using a low cost crystal and bill of materials. The high sensitivity combined with the integrated +20 dBm power amplifier yields industry leading link budget making it optimal for any application requiring range or robustness. LoRa™ also provides significant advantages in both blocking and selectivity over conventional modulation techniques, solving the traditional design compromise between range, interference immunity and energy consumption.

Due to the cost of this device, and its surplus of use, we will have to consider other options. Our design requires two receivers and two transmitters. This device is a transceiver and can reduce the cost by only purchasing two. If we used the LoRa Shield, opposed to something cheaper, this will cause too much of a burden on our budget.

### **3.2.6.2 nRF24L01 RF Module**



The nRF24L01 module is another great transceiver to consider, shown in **Figure 35** below. The nRF24L01 is a wireless transceiver module, meaning each module can both send as well as receive data. They operate in the frequency of 2.4GHz, which falls under the ISM band and hence it is legal to use in almost all countries for engineering applications. The modules when operated efficiently can cover a distance of 100 meters (200 feet) which makes it a great choice for all wireless remote controlled projects.

The module operates at 3.3V hence can be easily used with 3.2V systems or 5V systems. Each module has an address range of 125 and each module can communicate with 6 other modules hence it is possible to have multiple wireless units communicating with each other in a particular area. Hence mesh networks or other types of networks are possible using this module. So if you are looking for a wireless module with the above properties then this module would be an ideal choice for you.

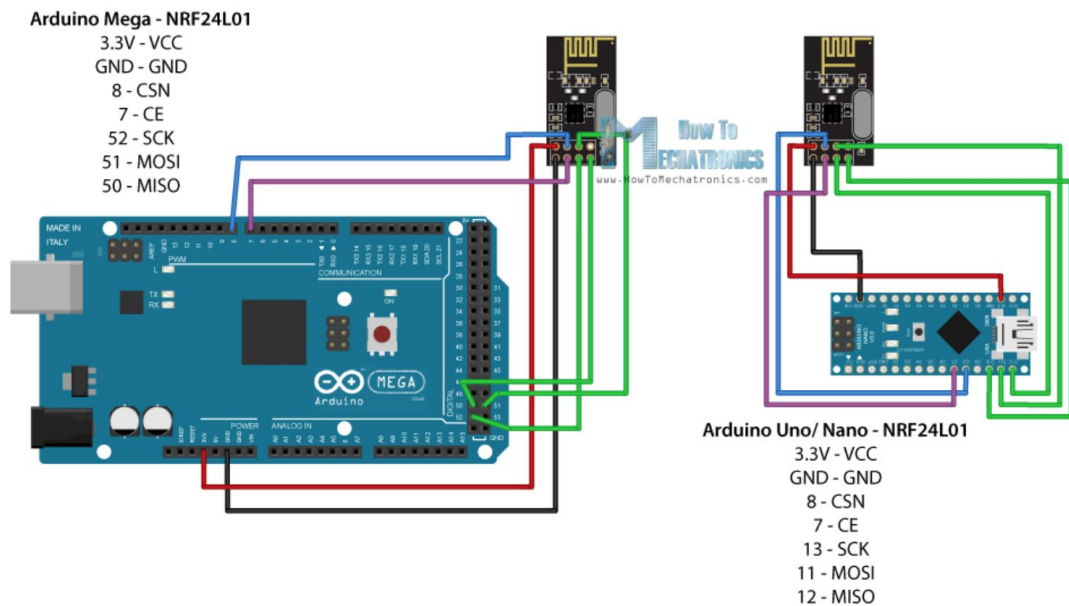

Figure 35: Arduino & nRF24L01 Integration

Because this device is extremely popular and cheap, it is a very good choice to consider for wireless communication between our arduino chips. In addition, this device provides low power consumption and great range communication.

### 3.2.7 DC Motor Controller

This section will consider individual components that can be used to control our motor operation through signals. This is again important to implement proper steering, driving, braking, and turning our robot. We will go through multiple devices that are capable of doing this and differentiate between which features are needed and which are not. The diagram below is a simple explanation of the way a motor controller interacts with controlling motors and interacts with receiving commands from the microprocessor.

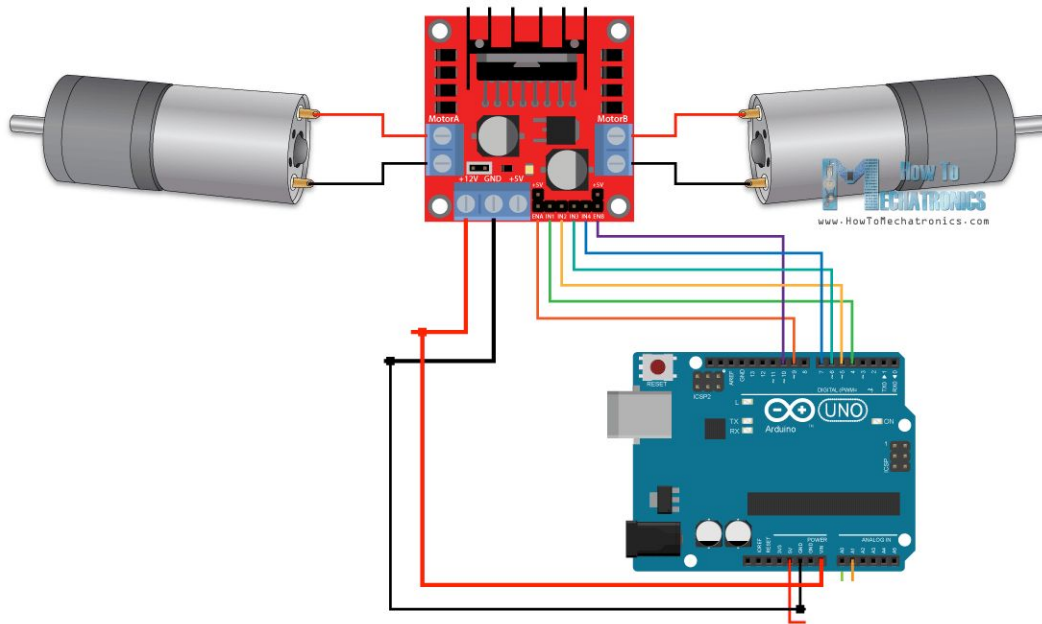

Figure 36: Motor Controller Operation Diagram

### 3.2.7.1 Sabertooth 2x25 Motor Controller

The first motor controller we are considering to choose for our design is the Sabertooth Dual 25A Regenerative Motor Driver. This motor controller has many key features that make it suitable for our needs, the most important of which is its power delivery. The Sabertooth can control two motors simultaneously, delivering 25A of continuous current to each (with a peak current of 50A). While this is certainly more current than we need, it provides the stability and robustness that we require while simultaneously ensuring that our motors will never burn out due to voltage drops (assuming an adequate battery). Moreover, the Sabertooth has added features that make it ideal for our project. For example, this motor controller, shown below, has regenerative braking/reverse, a feature that recharges the onboard battery whenever the motors are reversed or slowed. As a result, we have the ability to constantly recharge our battery by running our design backwards, allowing us to provide the same cutting pattern (in reverse)



while reducing the need for the operator to manually recharge the battery i.e. plug it into an AC outlet for several hours.

Another key feature of this motor controller is its ability to be controlled via multiple modes: R/C, analog, and serial. This flexibility allows our control method to change without having to significantly change the on-board hardware; for the purposes of future expandability, this is a desirable function to have. However, for our purposes, we will be using pulse-width modulation (PWM) via our microcontroller, which can be used in either the analog or serial modes. We will ultimately use the analog mode with the output of the microcontroller running through an RC filter (as per the Sabertooth's specifications). And, as an added feature for these modes, the Sabertooth provides a set of DIP switches to manually change the settings of each mode (response, signal mixing, etc.), making it even simpler to tune our design as this does not have to be via software.

Finally, the Sabertooth has some general characteristics that make it ideal for our design: it operates at a supersonic frequency (32 kHz), eliminating the 'whine' of the motor while it's operating; it has onboard heat sinks and heat dissipation, additional elements that we will not have to design or purchase separately (leaving us with more time and more money to complete our design); it has a variable input voltage operating range (6-30V), giving us flexibility in choosing our power source; it does not require the motors to come to a complete stop before reversing, resulting in much smoother operation; and, it is available at many online retailers, resulting in a short lead time and little chance of unavailability. The only real consequence of choosing the Sabertooth 2x25 is its price: \$125. However, given the total cost of the other components of our design relative to our funding, the Sabertooth has little overall budgetary impact, and its many positive features make it the ideal motor controller for our project.

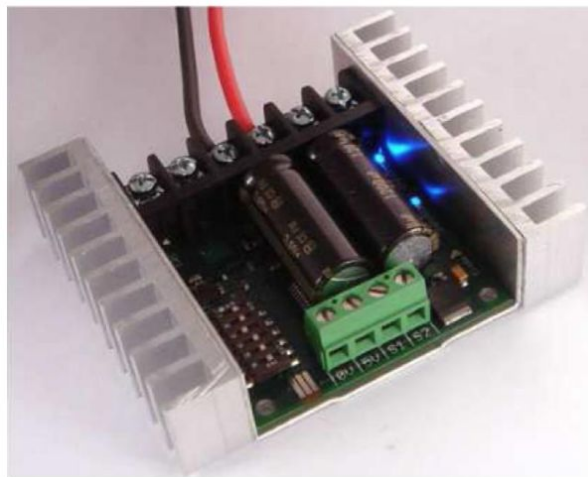

Figure 37: Sabertooth 2x25 Motor Controller

### **3.2.7.2 Syren 50A Motor Controller**

The second motor controller we will look at for our design is the Syren 50A Motor Driver. This motor controller has many key features that make it suitable for our needs, the most important of which is its power delivery. The Syren, shown below, can control one motor, delivering 50A of continuous current (with a peak current of 100A). While this is certainly more current than we need, it provides the stability and robustness that we require while simultaneously ensuring that our motors will never burn out due to voltage drops (assuming an adequate battery).

Another important feature of this motor driver is that it's part of the same family of motor controllers as the one we chose for our wheel motors: the Sabertooth 2x60. As a result of this, we are able to communicate with both drivers simultaneously using a single UART TX line on our microcontroller. By utilizing the simplified serial protocol, we can send the same signal to each input port (S1) on the respective motor controllers and control which one implements the command via setting the S2 pin either logic high or logic low. Thus, our communication scheme is greatly simplified, and does not require multiple PWM protocols or RC circuits.

Additionally, utilizing a motor driver to control the blade motor provides us with the added benefit of being able to control the speed of the blade motor, a feature not found on the existing motor. While this was not one of our system requirements (or even a desired quality), we can potentially monitor the torque on the blade and adjust the speed accordingly, thus decreasing our overall power consumption. Or, we could implement a power-saving mode, where the blade ran at some fraction of its top speed – this setting could be adjusted manually by the user based on the type of lawn he has as well as some other environmental factors e.g. wet lawn, debris, etc.

As with most things, these many benefits come at a cost – which, in this case, is the actual cost of the Syren, at \$125. However, as with almost all of our other components, we have ample room in the budget for them, and the sheer volume of the benefits of the Syren outweigh its only real drawback.



Figure 38: Syren 50A Motor Controller

### **3.2.7.3 Arduino Motor Shield R3**

The most suitable motor controller is that of Arduino. The Arduino Motor Shield Rev3 motor controller will be easily implemented with our Arduino MEGA board.

The Arduino Motor Shield is based on the L298 (datasheet), which is a dual full-bridge driver designed to drive inductive loads such as relays, solenoids, DC and stepping motors. It lets you drive two DC motors with your Arduino board, controlling the speed and direction of each one independently. You can also measure the motor current absorption of each motor, among other features. The shield is TinkerKit compatible, which means you can quickly create projects by plugging TinkerKit modules to the board.

Some of the specs of this arduino controller are:

- 5V to 12V operating power.
- Has the ability to drive 2 separate DC Motors
- 2 Amps max current per DC motor
- Cheap (~\$22)

### **3.2.8 Motor Blade Controller**

This section will consider individual components that can be used to control our motor blade operation through signals. The main difference between this motor controller and the last is that this one will require less voltage/ampereage due to the fact that this will only be propelling a nylon string instead of the large load of

driving our device. We will go through multiple devices that are capable of doing this and differentiate between which features are needed and which are not.

### 3.2.8.1 DROK L298

The DROK L298 is one of the simplest motor controllers. Due to its simple design and low power input/output properties, it makes a perfect candidate for our blade motor controller. As stated above, the blade motor controller is something that doesn't need as much strength as the drive motors. The DROK DC motor driver has an input voltage range of 6.5V-27V (DC), and can be input DC 12V or 24V, rated output current of each port is 7A, total output power is 160W. The motor controller board adopts dual H bridge, can drive two DC motors at the same time. The IN1, IN2/IN3, IN4 port can control forward or reverse motor rotation. The PWM signal enable signal terminal (ENA) input PWM can regulate speed, PWM frequency range 0-10KHZ. The motor driver module is with under voltage protection to prevent instantaneous large current from damaging the module.

### 3.2.8.2 SainSmart L293D Motor Driver Shield

The L293D Motor Driver Shield is almost perfect for our blade motors. Our design consists of 3 blade motors. If we could, we would like to only purchase one motor controller to minimize cost. The L293D is perfect for this. This Motor Drive Shield is a monolithic integrated, high voltage, high current, 4-channel driver. Essentially, when using this driver, you can operated using DC motors and power supplied up to 10 Volts. This device will stem from our 9V node of our PCB voltage regulator design. In addition, this device, shown in **Figure 39**, is easily integrated into our arduino system. Many different projects online show the simple integration of this with arduino.

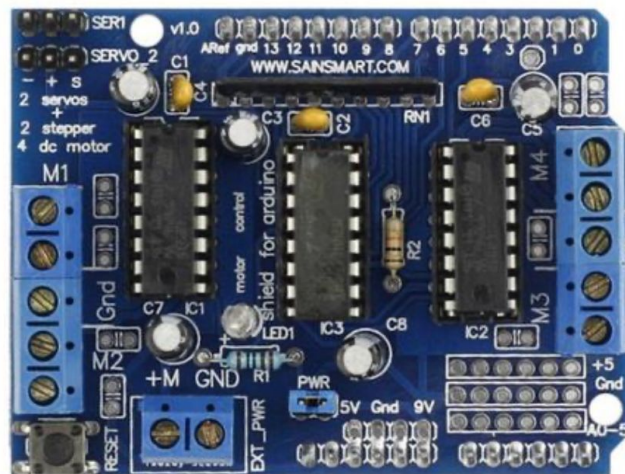

Figure 39: SainSmart L293D Motor Driver Shield

### **3.2.8.3 Cytron 4 Channel Motor Controller**

The Cytron 4 Channel 7-25V, 1.5A Brushed DC Motor Controller is specially designed to drive 4 DC brush motors. Since PR19, Flexibot- Using Transwheel (PR19) is using it as motor driver; it is being named after this bot. However, the application of FD04A is not limited to the DIY project, PR19. It offers low cost and easy to use DC motor driver capable of driving up 4 DC brush motor, and the current can go up to 3-Ampere. With minimum interface the board is ready for driving motor with direction, start, stop and speed control. Some of the key features to this device are:

- Able to drive 4 DC motors at 2.5A (peak), 1.5A continuously
- Protection against overcurrent
- 2 LEDs as direction indicator for each motor
- 1 LED as a power indicator
- Industrial grade PCB
- Fully compatible with Arduino

### **3.2.9 Beacon**

The beacons purpose it to transmit a location signal to our remote control box. The beacon will also operate on its own power supply to avoid losing power. The beacon will be implemented inside our main system and will connected to our Arduino MEGA board. From here, the Arduino will capture the information from the beacon and send this information to our remote arduino controller box.

#### **3.2.9.1 NEO-6M GPS Module**

The NEO-6M GPS Module is a very suitable GPS locator for our project. It is very simple to use and is easily integrated with Arduino. The NEO-6M GPS module is a well-performing complete GPS receiver with a built-in 25 x 25 x 4mm ceramic antenna, which provides a strong satellite search capability. With the power and signal indicators, you can monitor the status of the module. Thanks to the data backup battery, the module can save the data when the main power is shut down accidentally. This device, shown below, is usually packaged along side with the 1575R-A antenna. This antenna is essentially used to extend the GPS locating capabilities of the device.

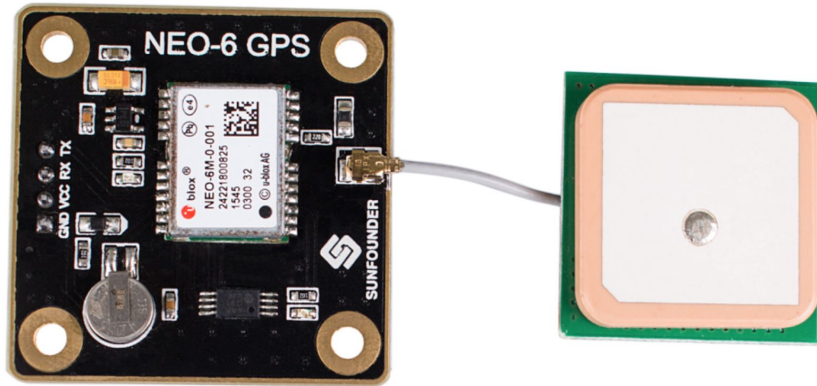

Figure 40: NEO-6M GPS Module with 1575R-A Antenna

### 3.3 Parts Selection Summary

This section is a final summary of all the components selected. The tables below will capture every part that we have discussed, and finally selected for our end prototype.

#### 3.3.1 Electrical Parts

This section of the report will go into detail about the specific electric components for our design. There will be a separate section which discusses the mechanical design.

##### 3.3.1.1 Battery Choice Summary

The battery is the most important part of any design that uses electrical parts, as you need some way to power the product so that it will do the task it was designed for. **Figure 41** is a trade matrix that was designed and discussed about what type of secondary battery we would use, and whether we would use only one type or multiple types of batteries. Each battery configuration was compared to five different criteria; cost, safety, available space, reliability, and overall weight. The larger the number under the evaluation section of the table counts as a better score for the configuration. Even though the best total score is determined to be the singular Lithium-Ion battery, we as a group decided that it would be more effective overall if we used a Lead-Acid battery to power the

motor and servos, while the Lithium-Ion battery to power the electronic circuit boards and sensors.

Batteries		Evaluation						Score				
Criteria	Weight of Importance	One Battery: Li-Ion	One Battery: Ni-MH	One Battery: Lead-Acid	Two Batteries: One Lead-Acid One Li-Ion	Two Batteries: One Lead-Acid One Ni-MH	One Battery: Li-Ion	One Battery: Ni-MH	One Battery: Lead-Acid	Two Batteries: One Lead-Acid One Li-Ion	Two Batteries: One Lead-Acid One Ni-MH	
Cost	3	3	2	2	3	2	9	6	6	9	6	
Safety	4	4	4	3	3	3	16	16	12	12	12	
Available Space	3	5	5	4	3	3	15	15	12	9	9	
Reliability	4	3	3	3	5	5	12	12	12	20	20	
Weight	3	5	5	3	2	2	15	15	9	6	6	
Total Score							67	64	51	56	53	

Figure 41: Battery Trade Matrix

### 3.3.1.2 Sensor Choice Summary

The sensors are one of the more important parts of any design that needs to determine where it shall gather its information from. The Sensors allow the design to “see” the world around it. **Figure 42** is a trade matrix that was designed and discussed about what type of sensor we would use. Each sensor type was compared against five different criteria; cost, energy consumption, available space, reliability, and overall weight. The larger the number under the evaluation section of the table counts as a better score for the configuration. The best score from the final tally comes from the LiDAR. While it has the highest weight and cost, it is offset by how much information the microcontroller is given by this sensor. An entire internal map can be created using a lidar that will update with near real-time accuracy, thus allowing for the EGOAT to determine if an obstacle is added to the pathway.

The main downside to the ultrasonic sensor is with the EGOAT being a lawn mower, alot of vibrations will be generated due to the spinning of the motors for the trimmer and wheels. This will cause a disturbance in the air around the robot, thus lowering the efficiency of the ultrasonic sensor and overall performance of the design. And infrared sensor can be added to the configuration in conjunction with the LiDAR as a fail safe, should the LiDAR miss an obstacle.



Sensors		Evaluation			Score		
Criteria	Weight of Importance	Ultra Sonic	Infrared	LiDAR	Ultra Sonic	Infrared	LiDAR
Cost	3	5	4	2	15	12	6
Energy Consumption	4	3	3	3	12	12	12
Available Space	3	5	5	5	15	15	15
Reliability	5	2	3	5	10	15	25
Weight	1	5	5	4	5	5	4
				Total Score	57	59	62

Figure 42: Sensor Trade Matrix

### 3.3.1.3 Microcontroller Choice Summary

The microcontroller(s) is(are) the second most important part(s) of any design as the microcontroller is the “brains” of the design’s functionality. These controllers manage the sensors, power output, and other information through the pins that send the data to each different component. **Figure 43** is a trade matrix that was designed and discussed about what type of microcontroller we would use. Each microcontroller type was compared against five different criteria; cost, energy consumption, available space, reliability, and overall weight. The larger the number under the evaluation section of the table counts as a better score for the configuration. The best score from the final tally comes from the Arduino. We were delighted with this turn of events as we were most familiar with using an Arduino as the controller for our design. This allowed us to use the knowledge we have gained for our design and made it easier for us to create the coding and connect the sensors and motors to the pins of the microcontroller.

Microcontrollers		Evaluation			Score		
Criteria	Weight of Importance	Arduino	Raspberry Pi	TI LaunchPad	Arduino	Raspberry Pi	TI LaunchPad
Cost	3	5	2	4	15	6	12
Energy Consumption	4	4	3	3	16	12	12
Available Space	2	4	4	4	8	8	8
Reliability	5	4	3	4	20	15	20
Weight	1	5	5	5	5	5	5
				Total Score	64	46	57

Figure 43: Microcontroller Trade Matrix

### 3.3.1.4 Arduino Choice Summary

For our Arduino microcontroller we had to determine which specific Arduino we wanted to use. **Figure 44** is a trade matrix that was designed and discussed about which Arduino subclass we would use. Each Arduino was compared to



four different criteria; cost, number of pins, available space, and reliability. The larger the number under the evaluation section of the table counts as a better score for the configuration. In the end the Arduino Mega was the best microcontroller to choose for our design, because the number of pins allowed us to add a multitude of different sensors or other parts to make the EGOAT more efficient without the need for an extra microcontroller.

Arduino		Evaluation					Score				
Criteria	Weight of Importance	Uno	Nano	Leonardo	Mega	Due	Uno	Nano	Leonardo	Mega	Due
# of Pins	4	3	2	3	5	4	12	8	12	20	16
Available Space	2	3	4	3	2	2	6	8	6	4	4
Reliability	3	3	3	4	4	3	9	9	12	12	9
Cost	3	4	5	3	2	2	12	15	9	6	6
Total Score							39	40	39	42	35

**Figure 44: Arduino Trade Matrix**

After all these considerations, the final parts list can be found below:

<u>Electronic Category</u>	<u>Part Chosen</u>
Microprocessor	Arduino Mega 2560
Proximity Sensor	LiDAR
Batteries	Lead-Acid, Li-ION
Voltage Regulator	LM2596
Transceiver	nRF24L01
Motor Drive Controller	Sabertooth 2x25
Weed Wacker Motor Controller	Cytron 4 Channel
Beacon	NEO-6M GPS
Main Battery	Lead Acid 12V 7A
Beacon Battery	Lithium Ion 3.7V

**Table 1: Final Parts**

### 3.3.2 Mechanical Parts

Upon doing a functional and component decomposition we did a deeper dive into some of the main components in order to find out what we will use for our final design. This included looking at wheels, cutters, materials, batteries, sensors, and microcontrollers that our robot will consist of. For the wheels, we looked at what type of wheels, how many, and the locations. For the cutters we looked into what types, how many, and the locations. For materials we compared materials to find the best for the frame of the vehicle. For batteries, sensors, and microcontrollers, the team looked into how many batteries and what type we need in order to power our robot, as well as what sensor and program we want to be able to control our robot. For each of these components we did a trade matrix that took the options for each function and compared it with how well it matched the criteria importance.

### 3.3.2.1 Weed Wacker Choice Summary

Figure 45 below shows the trade matrix for choosing what type of weed wackers we want to use and Figure 46 shows the trade matrix for choosing the number of cutters we wanted.

Weed Wacker		Evaluation		Score	
Criteria	Weight of Importance	Homemade	Off the Shelf	Homemade	Off the Shelf
Cost	3	4	3	12	9
Weight	2	4	2	8	4
Size	3	5	3	15	9
Reliability	5	3	4	15	20
			<b>Total</b>	<b>50</b>	42

Figure 45: Weed Wacker Matrix

Cutter Location		Evaluation				Score				
Criteria	Weight of Importance	1 Large Cutter	2 Cutters (2F)	3 Cutters (2F/1C)	4 Cutters (2S/2F)	1 Large Cutter	2 Cutters (2F)	3 Cutters (2F/1C)	4 Cutters (2S/2F)	
Cost	3	5	4	3	2	15	12	9	8	
Cut Width	4	2	3	4	4	8	12	16	16	
Cutting Efficiency	5	3	3	5	4	15	15	25	20	
						<b>Total</b>	<b>38</b>	<b>39</b>	<b>50</b>	42

Figure 46: Cutter Location and Quantity Matrix

Based upon the weed wacker evaluation, while looking at cost, weight, size, and reliability, we found that homemade weed wackers seemed to be the best option. After further talking to our sponsors, they recommended buying off the shelf

weed wackers. Due to this, we decided to go with off the shelf weed wackers. We also have decided to have three weed wackers in our design, with two being in the front and one being centered between the two but behind them. The reason for this was so that a larger grass cutting area could be achieved at once and so that the trailing cutter would be able to clean up any grass missed between the first two cutters. This would allow us to expand the cutting range as well as not rely on the front two trimmers being perfectly timed to not interfere with each other. The below shows the trade matrix for choosing the wheels on our robot.

### 3.3.2.2 Wheel Choice Summary

Wheels		Evaluation				Score			
Criteria	Weight of Importance	Centered Wheels	Tank Treads	2 Front 1 Swivel(R)	4 Wheels 2F/2R	Centered Wheels	Tank Treads	2 Front 1 Swivel(R)	4 Wheels 2F/2R
Cost	3	2	1	4	2	6	3	12	6
Maneuverability	5	2	5	4	4	10	25	20	20
Stability	4	2	5	3	5	8	20	12	20
Total						24	48	44	46

Figure 47: Wheels Matrix

The leading choice from the trade matrix for the wheels when considering cost, maneuverability, and stability as important criteria when choosing our wheel system was having tank treads. Tank treads we agreed on would still allow us to do a zero-turn and would keep the robot stable since the wheels would then stretch over the entirety of the robot. Even though tank treads were the highest option based off of this matrix, we decided to go with having four wheels since it was a close second option and would be less complex than building tank treads. With four wheels, we would have two in the front and two in the back, still providing stability in the robot for holding the weight of the housing and electronics. With this option, we plan to power two of the wheels and attach a chain in order to make it four wheel drive. The figure below shows the trade matrix for choosing the chassis material for our robot.

### 3.3.2.3 Chassis Choice Summary

The materials used in the design, shown in **Figure 48**, play a large part in the mower's effectiveness, affecting important aspects such as weight, durability, and cost. Without taking into account the specialized manufacturing that plastics provide, the main three considerations for structure materials are wood, aluminum, and PVC.

Chassis Material		Evaluation				Score			
Criteria	Weight of Importance	Aluminum	Wood	PVC	Steel	Aluminum	Wood	PVC	Steel
Cost	4	3	5	5	2	12	20	20	8
Durability	3	4	3	3	5	12	9	9	15
Constructability	5	4	3	3	2	20	15	15	10
<b>Total</b>						<b>44</b>	<b>44</b>	<b>44</b>	<b>33</b>

Figure 48: Chassis Material Matrix

Wood satisfies the majority of these criteria, but unfortunately falls short in the weight and durability departments when compared to metals like aluminum or steel. However, with a maximum horizontal shear stress around 1600 psi (averaged) and a maximum compression stress of about the same, wood possesses adequate strength for the purposes of this project. Additionally, cheap lumber is readily available from several sources and is relatively easy to shape and prepare when compared to metal or plastic counterparts.

Aluminum 3003 is another contender for comprising the chassis for the project, due to its high strength to weight ratio. With a yield strength of 25,000 psi, employing aluminum into the design will allow the rover to use much less material for the same strength as wood, causing the rover to become much lighter and easier to maneuver. Unfortunately, while the procurement availability of aluminum is fairly similar to that of wood, it is more expensive and significantly harder to shape and prepare for installation, which could lead to setbacks in the construction process.

PVC also offers its own set of advantages and disadvantages, namely its capacity for inexpensive mass production, which would be the obvious choice to create many units' chasses cheaply. PVC tubing is both lightweight and relatively strong, with a tensile yield strength of around 8000 psi, and easy to procure and shape, perhaps lending it the most advantages for a prototype.

## **4.0 Related Standards and Realistic Design Constraints**

This section will discuss the standards that are applicable to our EGOAT design, as well as any realistic design constraints that may apply to our project.

### **4.1 Related Standards**

Standards are documents that describe the procedures and specifications for manufactured products so that companies and ordinary people know that the product that is being purchased is of quality design. All standards are a baseline of procedures and guidelines that manufacturers and developers use when implementing different products in their designs.

There are many organizations that provide standards for the use of manufacturers and developers. One of which is the American National Standards Institute (ANSI), “a private, not-for-profit organization that is dedicated to supporting the U.S. voluntary standards and conformity assessment system and strengthening its impact, both domestically and internationally,” and is the main administrator of the *NSSN: A National Resource for Global Standards*. They are determined to “enhance the global competitiveness of U.S. businesses as well as the U.S. quality of life by promoting and facilitating voluntary consensus standards and conformity assessment systems, and safeguarding their integrity.”

Standards are created so that the quality of life for everyone using these products are increased, and so all products are starting with the same baseline safety precautions can then be designed to the customer's needs.

The committees and organizations, described above, are responsible for the creation of the standards that are going to be used in the designing process for the EGOAT, expanded in the following subsections, constitute only a small percentage of the total amount of organizations dedicated to producing the standards all developers use. The reason that there are so many different organizations is that standards can be accepted on a global, domestic or even company levels.

#### **4.1.1 Electrical Standards**

This section contains all the standards that pertain to our project's electrical design. These are being referenced to keep the electrical components used in a controlled and safe environment that allows them to operate at maximum

efficiency for as long as possible. These standards will also all for ease of troubleshooting with any products and components. It helps explain in depth what goes on with the certain schemes and operations of the components.

### **4.1.1.1 Battery Standards**

The beginning of any design for electrical engineers is how the system is going to be powered, whether by outlet or battery. Due to one of our constraints being that the EGOAT needs to be powered by a rechargeable battery, our EGOAT design will incorporate the use of a battery. Below are a couple of standards that have an impact upon our design, or any future modifications to the design.

The battery's load is the current that is created between the battery and load circuit. When it comes to the current, there are a couple types of current situations we must be aware of:

- Starting current: The current drawn when the system is powered on initially.
- Parasitic currents: These are currents that are drawn from measurement devices like a charge controller.

These are some factors of current that need to be thought about when designing a system that uses a stored power cell. When it comes to the temperature of the battery, the temperature is directly proportional to the capacity of the battery. Designing this system will take measures like knowing the time the battery will be used, the amount of current that will be drawn from it.

#### **4.1.1.1.1 IEEE Std 1187-2013**

The battery standard IEEE Std 1187-2013 talks about the recommended practical application and installation for Valve-Regulated Lead-Acid batteries. This standard recommends design practices and procedures for storage, location, mounting, ventilation, instrumentation, preassembly, assembly, and the charging of valve-regulated lead-acid (VLRA) batteries.

#### **4.1.1.1.2 IEEE Std 1188-2005**

The battery standard IEEE Std 1188-2005 is IEEE's recommendation for the maintenance, testing, and replacing of Valve-Regulated Lead-Acid batteries. The standard will help with protecting ourselves and the system as a whole should something damage the battery during operations. Within the document, the most

important information within is the safety section of the standard. Within it it documents

#### **4.1.1.1.3 IEEE Std 1013-2007**

The battery standard IEEE Std 1013-2007 talks about the uses of Lead-Acid batteries for photovoltaic (PV) systems, which will not be used for the design of our EGOAT. However, future designs could incorporate a solar panel on the back, or top, of the body of the EGOAT that charges the battery when sunlight is shining on the panel, thus incorporating this standard into future designs.

#### **4.1.1.2 PCB and Soldering Standard**

The J-STD-001F is an industry standard that prescribes practices and requirements for the creation of soldered electrical and electronic equipment. The purpose of this standard is to describe materials, methods and acceptance of protocol for the completion of electrical soldered equipment that shall be both safe and of a high quality. Through the application of this document it shall provide quality control for manufactured products that contain a soldered electrical and electronic assembly. There are two other documents that can be used in conjunction with J-STD-001F that can help provide clarity with its implementation by providing both visual assistance and additional information. IPS-HDBK-001 is a handbook and guide meant to supplement J-STD-001F and it gives additional information relating to the processes and the reasoning behind why the current processes are being used. IPC-A-610 F is a standard that shows a collection of visual quality for the acceptance of requirements for electronic assemblies.

The J-STD-001F standard contains a set of classifications for the electrical equipment which is determined by the end-item usage. There are three general end-product classes that have been established to showcase the differences in complexity, productivity, performance requirements, and verification frequency. It should be acknowledged that there may be overlap of equipment between classes. The different classes are:

- Class one: General Electronic Products- Includes products where the major requirement is the function of the completed appliance.
- Class two: Dedicated Service Electronic Products- Includes Products where continued performance and extended life is required. Usually with uninterrupted service, though it is not necessary.
- Class three: High Performance/Harsh Environment Electronic Products- Includes products where continuous high performance and/or continued service is critically required.

The classification that the EGOAT qualifies for is for class one and class two. Class one's procedure will be implemented for the designing and building of the EGOAT, while class two's procedure shall not be needed until the EGOAT is industrially applied. The below table lists general specifications that will be used as a part of the fabrication of the PCB and will be used regardless of class.

Board Type	Design Specification	Fabrication Specification
Generic Requirements	ICP-2221	ICP-6011
Rigid Printed Boards	ICP-2222	ICP-6012 ICP-A-600
Flexible Circuit Boards	ICP-2223	ICP-6013
Rigid Flex Boards	ICP-2224	ICP-6013

**Table 2: Design, Fabrication and Acceptability Specification**

The major elements that are covered in the J-STD-001F are flux, solder paste, solder alloy and soldering system. Whenever one of these processes are changed it is important to check that the new one still adheres to the standard. Solder shall be in accordance with J-STD-006 which describes requirements and test requirements for electronic grade solder alloys for both fluxed and non fluxed. Solder that is considered lead free should be used as a preference and should contain less than .01% by its actual weight. The solder paste that shall be used in accordance with J0STD-005 which is a joint industry standard for the testing and specification to produce high quality electronic connections.

There are many more important considerations within this soldering standard that affect the design and building process. Some of the standard's listed requirements within the document include instructions and data for surface mounting, wire setup, through hole mounting, and general soldering and assembly requirements.

## **4.1.2 Software Standards**

This section contains all the standards that pertain to our projects software design. These are being referenced to keep the software coding used in a controlled and safe environment that allows them to operate at maximum efficiency for as long as possible. These standards will also all for ease of



troubleshooting with the coding. It will help explain in depth what goes on with the certain schemes and operations of the components.

### **4.1.2.1 IEEE 829-2008**

The IEEE 829-2008 standard is known as the standard for software and system test documentation, and is a standard that specifies a set of documents for use within eight defined stages of software testing and system testing, with each stage potentially generating its own set of documentation. Some of the documents within this standard are:

- Master Test Plan (MTP): Which provides overall test plans and management documents for multiple testing levels.
- Level Test Report (LTP): The scope, approach, resources, and schedule of the testing for each specified level of testing needs to be described. The items, features, tasks, responsibility, and risk(s) need to be identified.
- Level Test Design (LTD): Details test cases and the expected results, as well as the testing pass criteria.
- Level Test Case (LTC): Specifying the test data for the use in running the test cases identified in the Level Test Design.
- Level Test Procedure (LTPr): Detailing how to run each test, including pre-conditions and any steps that need to be followed.
- Level Test Log (LTL): To provide a chronological record of relevant details about the execution of tests, whether they passed or failed.

### **4.1.2.2 ISO/IEC 9899**

ISO/IEC 9899 is an International Standard which talks about the different ways and methods you can use the C language and how to implement it. The standard talks about several different sections about C: Scope, Terms and definitions, conformance, environment, language, and library.

The Standard's scope goes over the topics like the representation of C programs, the syntax, and semantic rules for interrupting programs. The standard starts off defining key words that are used within C program. This standard applies to software design which will be used in the software aspect of our project. There are a list of definitions and rules that have been given in the standard that will help understand the standard in its entirety. In the standard there are a number of environments that are defined. A freestanding environment is where a program execution can operate "without any benefit of an operating system." There is a section within the standard that explains the language and topics like notation, concepts, and conversions. The standard explains different types that can have

values to them. The types range from integer, character, floating, array, structure, boolean, and pointer types. These all have their own attributes and can be used in specific types of executions.

### 4.1.2.3 Arduino IDE and Language

The Arduino integrated development environment (IDE) is a software development platform with integrated toolchain that is widely popular amongst hobbyists and professionals alike. Because of its widespread popularity in both prototype and product scenarios and the open source nature of its toolchain, it is widely supported by many microcontroller manufacturers and integration libraries for a large number of other products.

The language of the Arduino IDE is essentially a dialect of C/C++ augmented with a library with common microcontroller functionality and slightly different source code formatting rules. Rather than a *main* function as in standard C, and Arduino requires a *setup* and *loop* function to run which are then linked to a stub *main* function at compile time. The linked code then is then compiled with the standard GCC toolchain and the resulting binary is encoded as a hexadecimal representation within a plaintext file that can be serialized into the microcontroller's memory. So long as the microcontroller supports this method of compilation, this allows developers access to an extremely rich, highly cross-compatible library and easy installation without losing the advantages of bare metal programming.

## 4.2 Realistic Design Constraints

For all projects that are being built, there needs to be design constraints built into the designing process that dictates what can and cannot be put into the project. The EGOAT is required to use a battery powered trimmer that is commercially available, and uses a string as the implement to cut the grass, as using a metal blade would be less cost effective and more dangerous to implement. This will allow our design to use a higher quality trimmer than if we were to design the trimmer ourselves. The use of an off-the-shelf battery and charger limits our design to secondary batteries, and limits our power design of the prototype.

The EGOAT must operate independently and have no attachments to the solar farm infrastructure. Our design doesn't include any schematics for attaching the EGOAT to any infrastructure, with a possible exception for the charging dock that might be required within the project diameters.

Constraints can be determined by the client as part of their requirement specifications, by the manufacturer as a part of their resources and by the designer as part of their technical knowhow, as to what parts would have the best compatibility with other parts and the overall design. All constraints must be determined as realistic for the complete set to be considered as a part of the final design process. The constraints are usually determined by looking at a general problem, and are used as an improvement of society and quality of life by the observation of the factors that determine everyday decisions, such as:

- Economic
- Time
- Environmental
- Social
- Political
- Ethical
- Health
- Safety
- Manufacturability
- Sustainability

### **4.2.1 Economic and Time Constraints**

Economic constraints are external constraints that limits the part selection for the designers of the project, as companies will not be able to fund a project should it The budget of the EGOAT, which has been provided by our sponsors, Orlando Utility Commission and Duke energy, is \$1500. This will tried to be split equally between two sections, the mechanical components and the electrical components. It would not be economically viable to purchase, or plan to purchase, the most advanced option due to our limit, therefore a less advanced technological device would be more viable.

On top of economic constraints there are time restrictions that will work with and against the designers. These restrictions allow for the management of the design process in an efficient and orderly manner. Research for and a design draft of the circuitry should be completed by December 5, 2019. After the completion of the research and design, testing and manufacturing of the circuitry of the EGOAT will begin. The completed EGOAT will be presented at the end of the 2019 spring semester which will be in May. The completion of the circuit design and component selection by December 5th should allow for suitable amount of time for any redesigns that are needed and part retrieval for the final prototype design. The importance of time constraints should be kept in mind that if the best option for a design exceeds the deadline for the final project. Within the Milestone section, a gantt chart will be added showing relatively when and how long it took to complete certain tasks and milestones.

## **4.2.2 Environmental, Social, and Political Constraints**

There are very few designs and manufacturers for autonomous lawn mowers out in the business world. The charger design will allow for a lower carbon footprint due to the fact that the EGOAT's battery will be able to be recharged eliminating the need for the battery to be replaced often.

Our design will try to push the limits on how cheaply we can design and prototype our EGOAT, while still keeping the reliability of a high end product. This is off the hope that someday our design could be the launching point of a future design that could become an everyday household product. The introduction of another design for an autonomous lawn mower, could generate more ideas for other products that can create more competition in another job field.

## **4.2.3 Ethical, Health, and Safety Constraints**

Lawnmowers are dangerous, especially ones with metal blades. Luckily, our sponsors constrained us into only using a string based trimmer. This will significantly reduce the risk of accidental dismemberment, or destruction of the solar farm equipment. The wire trimmers should not be exposed along the outside of the rover's body, should this be a part of the design, coverings for the trimmers should be designed and installed to decrease the risk of injury without reducing the efficiency of the overall design. All electrical components should be covered and a sufficient cooling system should be installed so that the devices do not overheat and cause any accidental damage to the environment, the device itself, or any equipment in the area. Careful consideration of the positioning of all wires should be accounted for so that each and every component is properly grounded.

It should always be kept in mind that there are some designs, physical components or software designs that are protected by patent or copyright law and should not be used unless given written permission by the owner of said patent or copyright. All information pertaining to the design of the EGOAT should be documented for future use or for validation purposes, whether the idea was original or not.

Safety is a major factor to consider when building any product that a customer will use. For typical lawnmowers, many incidents from cutting to amputations have occurred since there are usually rotating blades. Due to this, standards have been implemented to reduce the number of cuts and amputations caused

by lawnmowers. One standard required is to have a protective shield around the spinning parts or blades. This is to protect the feet, especially on a push or walk behind mower, from getting caught or contacting the blades during operation. Another purpose for the protective shields is to help direct the trajectory path of debris once struck by the spinning blades. While, our autonomous lawnmower will not have blades and will have strings for trimmers, this is still important to take into consideration as a fast spinning nylon string can still cause welts or cuts. Due to this, having shields around the cutters is something we would like to take into consideration when designing and building.

Over the years, the types of powered lawnmowers and their structures or features have evolved for safety purposes. Today, handles on mowers have levers that must be held down in order to keep the mower running. This allows for if for some reason, someone let go of the mower because they tripped, or are distracted by something else and do not currently have control of the mower, the mower does not have the capability to keep spinning its blades and it limits the possibility of unexpected accidents. Obviously being autonomous, we would not need to worry about someone losing self control over the lawnmower but this gives a valid idea of implementing a handle onto our lawnmower. Attaching a handle to the top of the lawnmower would allow someone to transport the lawnmower easily as well as grab it in a safe zone if need be while the lawnmower is running in order to control its path of motion.

Another feature applied to some lawn mowers is a blade-brake clutch system. This allows for a way to turn off the motor blades without killing the motor and having to restart everything if a break was needed for a few minutes like taking a phone call. While our robot would not have a blade-brake clutch system, it will have a physical and remote kill switch to power down the lawnmower if deemed necessary or to stop malfunctions.

Now days, similar to in vehicles, riding lawn mowers are equipped with a feature to make them beep loudly when backing up to alert others around to stay out of harm's way. This is something we also plan to implement is a sounding system that will go off and alarm anyone if the robot detects it is approaching an obstacle.

The table below includes some of the requirements and specifications for our design:

**Table 3: Safety Requirements**

#	Requirement	Reason
1	The rover must be capable of safely navigating in uneven terrain (~ 3 inch terrain differential over ~ 2 foot span in any direction) without capsizing while avoiding a series of obstacles.	To prevent any damage to the land the solar farm is on so that no animals, or humans could be harmed should the rover capsize.
2	Avoid any damage to surrounding infrastructure, the environment and humans.	To prevent any liability to fall upon the company do to preventable injuries.
3	Robotic rovers must use an off-the-shelf battery powered trimmer (no metal blade – must be string-based) to cut grass.	

#### **4.2.4 Manufacturability, and Sustainability Constraints**

Manufacturability constraints restrict the components that are able to be used with the design of the project, determining whether the component is easily manufactured or not. The manufacturing functions that we, the designers, should keep in mind is how well the product can be fabricated, how readily it can be assembled, the ease as to it can be tested, how easily it can be acquired, the punctuality of shipping, and the difficulty of repairing the component. The accessibility of component limits us to services that are commercially available to us, though it can be expanded through the use of some of our universities resources.

Sustainability constraints are incredibly important for our project due to the EGOAT being an outdoor autonomous rover and thus will have to run in most weather conditions, especially in rain or thunderstorms due to the Florida weather patterns. Off the shelf components and commercial products are to be used so that the ease of construction and repairing the rover allows for the continued working of the overall project. Easy accessibility to all parts, while still making the chassis durable, will allow for increased longevity of the rover's life cycle

Sometimes Manufacturability and Sustainability constraints work exceedingly well together, such as the ease with which a metal chassis and plexiglass body fit together to create a decently great shield against the rain, which keeps the electrical components from getting soaked and shorting out or becoming damaged. However, in some different applications the opposite can be considered true, and manufacturability and sustainability constraints can have a negative impact on each other.

## **4.2.5 Customer Constraints**

Another set of constraints that designers need to keep in mind are the limitations the customer gives to the designers. Below are the constraints and requirements that Orlando Utilities Commission and Duke Energy have provided for us:

1. Robotic rovers must use an off-the-shelf battery powered trimmer (no metal blade – must be string-based) to cut grass.
2. The rover may consist of an off-the-shelf remote controlled system that is modified for the application but should still have an autonomous mode or capability.
3. The robotic grass cutting rovers must be equipped with a remote kill switch that can turn off the cutting system and locomotion at a distance of approximately 50 feet.
4. An off-the-shelf battery and charger must be utilized.
5. The rover must be capable of safely navigating in uneven terrain (~ 3 inch terrain differential over ~ 2 foot span in any direction) without capsizing while avoiding a series of obstacles.
6. The rover must be capable of safely navigating in uneven terrain (~ 3 inch terrain differential over ~ 2 foot span in any direction) without capsizing while avoiding a series of obstacles.
7. The system must operate independently and have no attachments to existing solar farm array structures.
8. Total system materials and assembly cost target: \$1500.
9. The ability to cut grass at an acceptable height (3 to 6 inches) is considered a plus. It is expected that teams will adapt and mount a commercially available string trimmer head to their devices.
10. The system must traverse the large areas and maneuver around PV support structures.
11. Avoid any damage to surrounding infrastructure, the environment and humans.

## **5.0 Project Hardware and Software Design Details**

This section of the report will introduce and describe our complete hardware design. The main goal of the hardware is to provide a stable, functioning environment for the software to execute as planned. In a similar fashion, the software will assist the hardware in operation. The system design is built around safety, efficiency, control, and functionality. The system design is not solely electrical. Considerations and design for mechanical device components were also completed through their own respective team.

### **5.1 Hardware Design**

Hardware is the term used to describe the physical components used in a design, while the software is the coding that tells the hardware what to do when an input is registered. This section will discuss the information that will be a part of each subsystem within the EGOAT and will consist of:

- Power System
- Electronic Device System
- Hardware Buffer Systems
- Mechanical Design
- Software Design
- Aesthetics

Aside from the topics above, this section will focus on individual component breadboard testing. It is important to realize what individual circuits need before integration into an entire system. The figure below lays out how we are designing how the parts will all connect to each other.



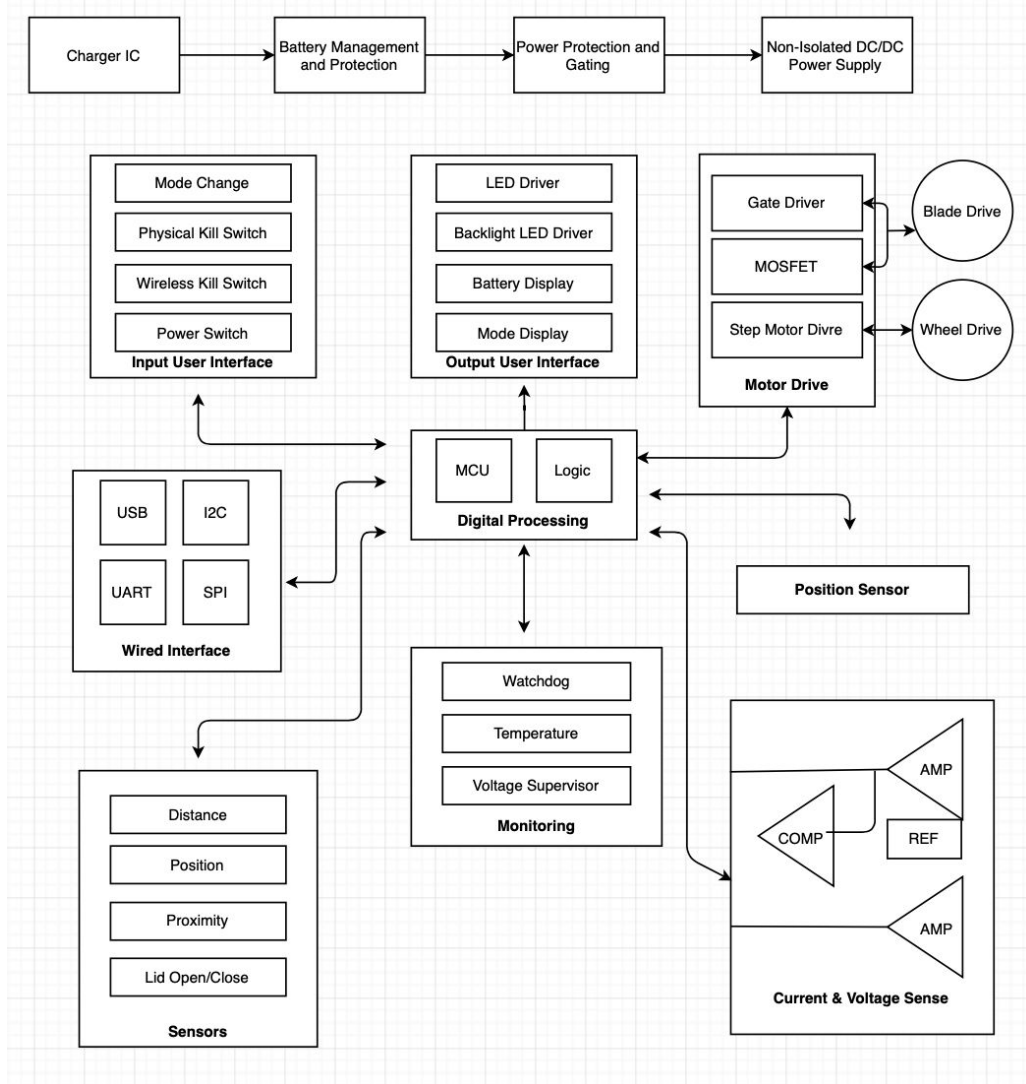

Figure 49: MCU Layout

### 5.1.1 First Sub-system: Power System

This section discusses the power system design. It is crucial to have proper power management. Without this, circuit components can easily overheat and become broken or damaged. The main power supply we are using is a 12V, 7A rechargeable lead acid battery. As discussed earlier, this battery is optimal for our design due. It will power almost everything in our system. Because many of the electronics do not require such a high voltage, we will need to step down the voltage for each subsystem. The power distribution and management will be delivered in a printed circuit board.

### 5.1.1.1 Overall Power Management

There are a number of components that need a voltage step down from our 12V source. We also know that we need to deliver an input voltage anywhere between 7V and 12V to our ATMEGA2560 arduino microprocessor. The chip has a built-in voltage converter that converts the input voltage to what is desired for optimal computation. However, in order to conserve as much energy as possible, we implemented a buck converter from the main power supply to power the arduino. Moreover, the voltage regulator will step down the input current from 7 A to 600 mA. This is necessary as the input current of the arduino cannot exceed 1A. Below is the beginning design of our voltage regulator. As well as our final schematic for the voltage regulator in **Figure 50**.

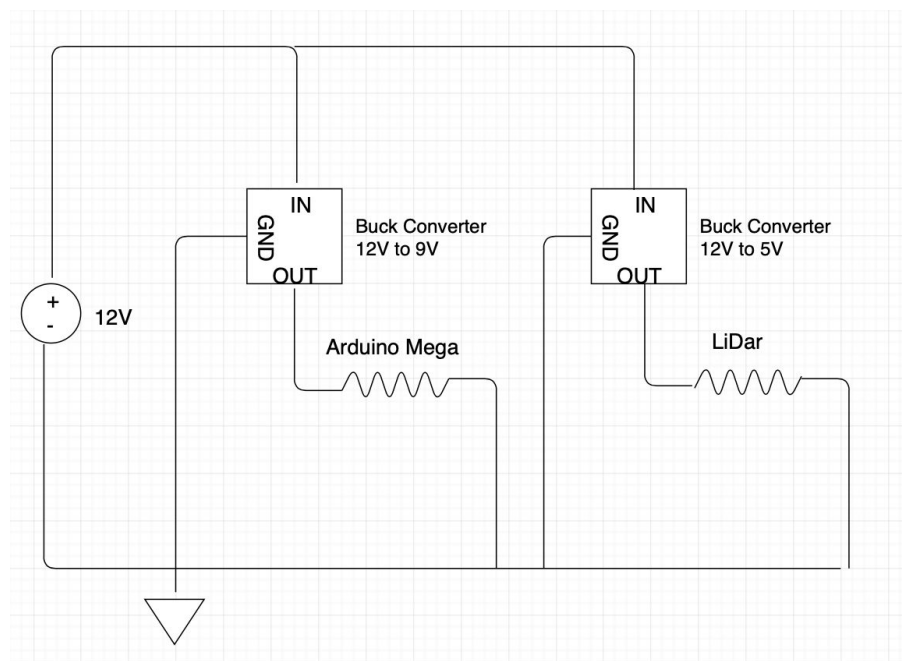

Figure 50: Voltage Regulator Design Idea

Additionally, we will need to design a separate step down circuit to provide the proper voltage to our Lidar system. The spec sheet of the Lidar we selected has limiting factors of a 5V. In order to provide the proper supply for the Lidar, we will need to build a second step down voltage. Both of these circuits will be implemented on the same PCB. In order to do this, we will use a similar regulator. However, this circuit has a different layout to achieve the consistent 5V output. We will be using the LM2596SX-5.0/NOPB to achieve our desired 5V output.

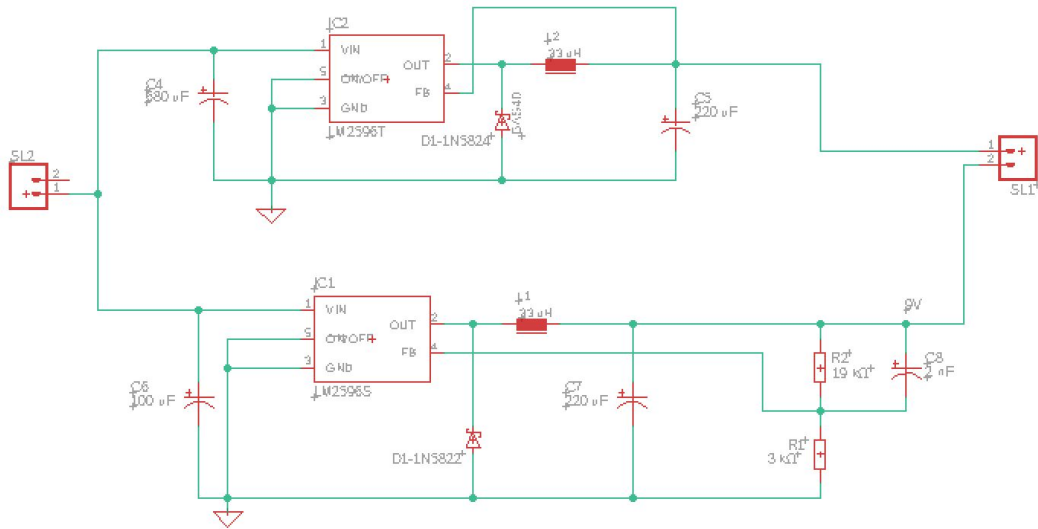
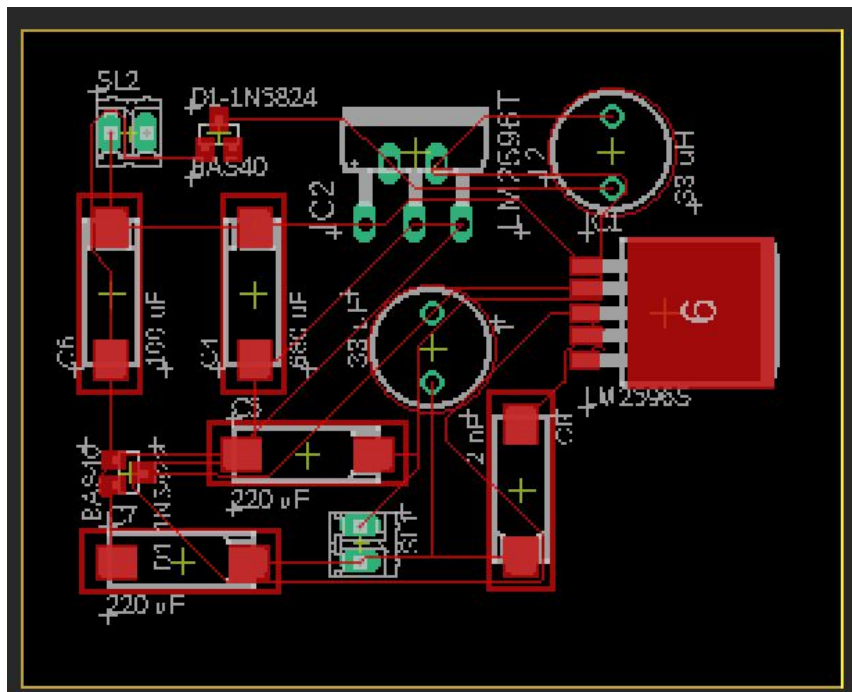

Figure 51: Voltage Regulator Schematic Design

This integrated circuit uses a series of operational amplifiers, feedback loops, and transistor switches that help create the output needed with help from external components like capacitors and inductors. Instead of taking the input and using voltage division or an op amp circuit, we chose to integrate the LM2596 for simplicity, consistency, and functionality.



## **5.2 Overall Integration**

This section discusses the overall integration of the project. This section will also focus on integration outside of the input power. Throughout the whole report we discussed various things that the project entails. Now, we will put all the pieces together. When we look at the entire system, our center piece is the Arduino Mega 2560. All components in the system are attached to the arduino in some manner. We will look at these subsections and discuss how they interconnect and how they work.

### **5.2.1 Remote Kill Switch**

In order to satisfy the required 50 foot kill switch, we decided that building a remote control box would be best. This remote will function off of an additional Arduino. We will be using the Arduino NANO. The purpose of this entire remote controller is to function as a remote kill switch and to track down the eGOAT through the means of a beacon. In case the eGOAT power supply is dead and the eGOAT cannot be found, a beacon inside the robot will be able to signal its location the transceiver in our remote.

### **nRF24L01 RF Module**

The nRF25L01 integration is important for long range communication. The main reason we are using the this is because of its simplicity with Arduino. As previously stated, our main goal of using wireless communication is for a remote kill switch.

nRF24L01 is compatible through the 3.3V port of the Arduino Mega. An additional component will order is the antenna required for signal sending and receiving. The way this will work is as follows: the arduino will receive power from the battery. The arduino will be able to communicate with the motor controller through a relay. The relay will allow communication to move forward, backwards, or turn. In order to shut down the connection between the Arduino and the relay, we have to include a driver circuit between the Arduino and the relay. This will give us the option to completely disconnect the Arduino processor from the relay controlling the motors.

Later on, we will discuss the software side of the implementation. This is where the nRF24L01 Shield comes in. We will use the nRF24L01 to communicate directly with the driver circuit. Depending on whether the kill switch signal is received will determine the status of the driver circuit. It is important that the kill switch works effectively and on the first try.

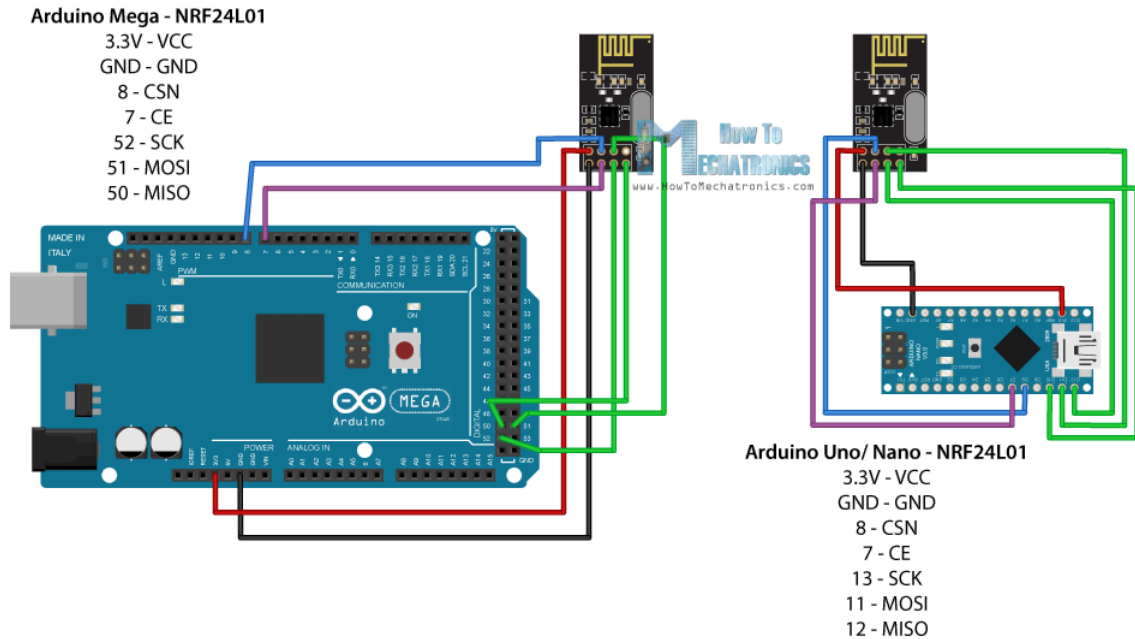

Figure 53: nRF24L01 and Arduino Mega Connection

## NEO-6M GPS Module

For our beacon, we will be using the NEO-6M GPS Module, shown below. As stated before, this module is fairly simple to use and easily integrated into the Arduino. Although this device can be powered by the 3.3V I/O pin of the Arduino, we will use a separate power supply. This is a requirement of the project.

The NEO-6M works with a frequency of 5 Hz. This means it sends the current GPS coordinates five times per second.

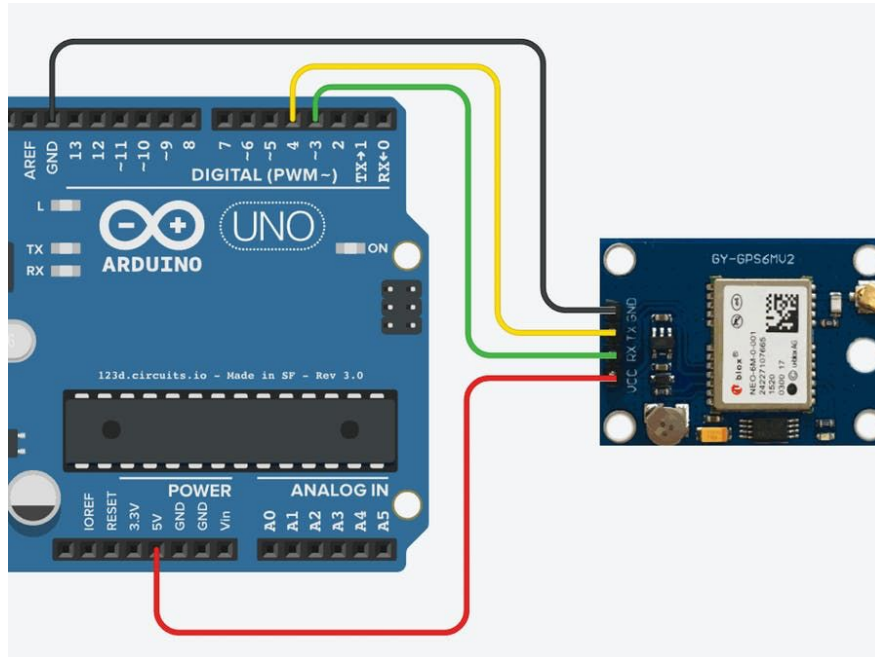

Figure 54: Arduino and Neo-6M Connection

## 5.2.2 Motor Integration

Our egoat will use a total of 4 motors. 2 for the wheel and 2 for the grass cutters. Integration will involve some form of testing to ensure that the motors are working and be integrated into our prototype egoat to replace the current parts we are using for the prototype. Integration should be seamless but evolve and change as features or parts are added.

### 5.2.2.1 Drive Motor Integration

Our final wheel motors will be integrated into our prototype and tested as our prototype egoat was tested. The wheel motors will be plugged into a 4-channel relay module that will be controlled via the arduino to ensure that the egoat can turn properly. The egoat will be much like front wheel drive car, meaning that the the arduino will drive only the front wheels so the egoat can operate. When wanting to turn left the arduino will rotate the front left wheel in reverse and maintain and steady rotation on the front right wheel going forward. This rotation is what would cause the egoat to turn left. Similarly when turning right the arduino will send the signal to the relay to cause the front right wheel to rotate in

reverse and the front left wheel to rotate forwards and this would cause the egoat to turn right. Going forward involves both motors rotating the wheels forward and reverse means both wheels spin in reverse. We are also looking into using a PWM motor controller that will interface with the arduino and the four-channel relay to be able to control the speed at which the motor rotates. Having this feature would provide our egoat with the ability to make more accurate turns as well as more precise turns at different angles. It would also allow for better obstacle avoidance such that the egoat can begin to slow before reaching an object and maneuver around it better to avoid the object.

### **5.2.2.2 Grass Cutting Motor Integration**

The grass cutting motors are designed to receive power straight from the battery in the prototype, will be tested in the same manner as the current grass cutters being used with the prototype. This will change however once the kill switch feature is added. There will be a relay added in the middle between the battery and the grass cutter motors to ensure that the power is cut and the grass cutters stop when the kill switch is engaged. The grass cutting motors will spin at their maximum speed in opposite direction to ensure they are cutting the grass correctly

### **5.2.3 Invisible Fencing**

A requirement of this project is to have a secondary safety kill switch. In the case of our remote kill switch malfunctioning, we are going to install a boundary remote kill switch. This can be extremely beneficial by keeping our robot in a specified zone. Ideally, our eGOAT will be able to travel inside the bounds of our wire fence freely. In addition, the eGOAT will act and turn around upon crossing the boundary. Due to the high cost of many invisible fences and GPS fences, our team is going to be designing and constructing our own. We will be designing to separate PCB boards: a wire generator and a sensor.

Wire guidance technology is widely used in the industry where handling is automated. As we discovered during our research, many automated lawn mowers contain this feature as well. Essentially, the robot follows a wire loop surrounding the perimeter of the zone. An alternating current of relatively low intensity and frequency between 5 kHz and 40 kHz flows in this wire. The robot is equipped with inductive sensors, usually based on a tank circuit that measures the intensity of the electromagnetic field close to the ground. A processing chain of amplification, filtering, and comparing makes it possible to determine the position of the robot within the wire.

## Wire Generator Design

The perimeter of the generator circuit will be based on the famous 555 timer. The 555 timer is an integrated circuit used for a timer or a multivibrator mode. For our design, we will be using the NE555 in Astable configuration. The two resistors and capacitors in the circuit make it possible for the oscillation frequency as well as the duty cycle. The arrangement of the components is shown below in the schematic. The NE555 timer generates a square wave which can run the length of the perimeter wire.

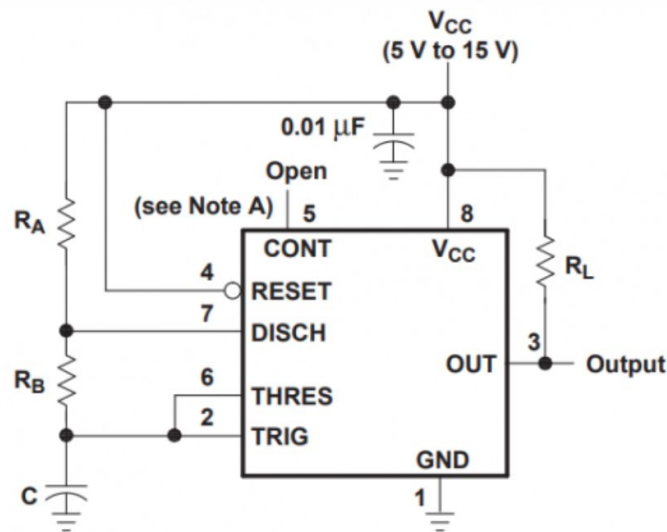

Figure 55: NE555 Timer Circuit for A-stable Operation

The formula used to calculate the frequency of the output square wave is:

$$f = 1.44 / ((R_a + 2 \cdot R_b) \cdot C)$$

The frequency range of the generated square wave will be between 32 kHz and 44 kHz which is a specific frequency that shouldn't interfere with other close by devices. A potentiometer will be used to help us vary the desired frequency to match our LC tank circuit. A few components were added to data sheet schematic, like the potentiometer, to account for what is needed to hook up our 555 timer.

The community of RobotShop completed this design and for the purposes of reliability, we will be using their PCB board and Schematic, it can be seen below.



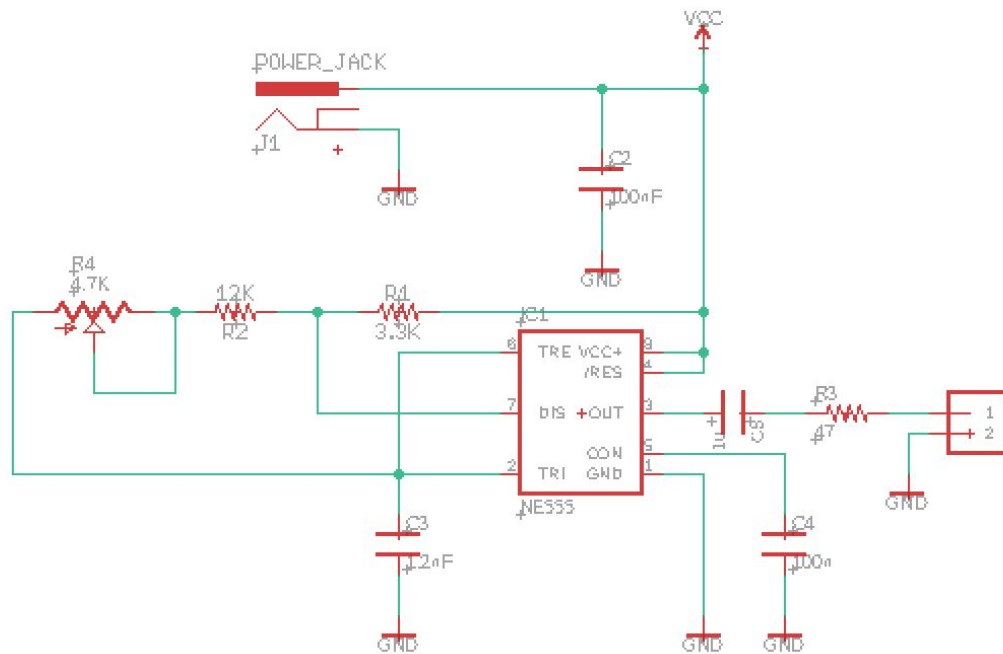

Figure 56: Wire Generator Schematic

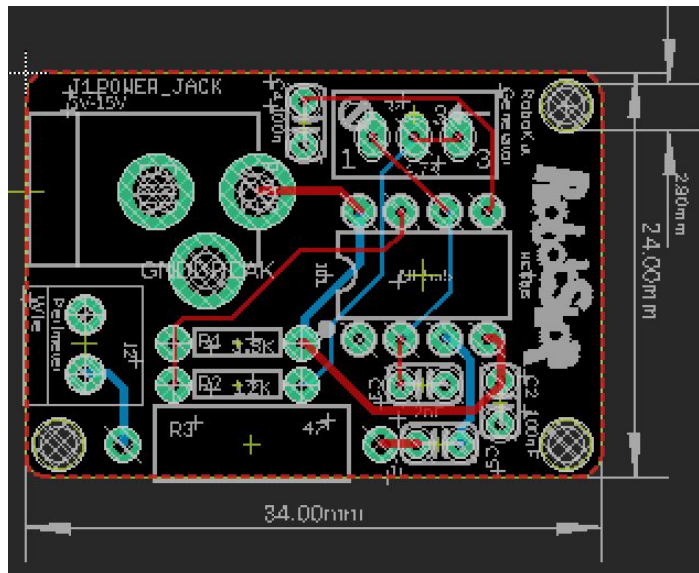

Figure 57: Wire Generator PCB

The installation of the wire will be implemented through pegs around the course to keep it in place. In addition, we will select a wire that is best suitable for our project. Since the system will most likely be left outdoors, it will need a weatherproof wire. Lastly, the PCB generator board will be kept inside a plastic shield to prevent water damage.

## Sensor Design

Now that we have completed the design for the generator circuit and confirmed its function output is what was desired, we can design the sensor. The goal of the sensor is to detect the generator wire and send an interrupt to our robot. This interrupt will let the robot know it is reaching the perimeter of the desired zone.

In order to design the sensor, we must first consider an LC circuit, or a Tank Circuit. A Tank Circuit consists of an inductor and capacitor in parallel. Essentially, this circuit can act as an electric resonator and store energy oscillating at the circuit's resonant frequency. Since our generator circuit is creating a waveform at a frequency between 32 kHz and 44 kHz, we must remain in this range for the sensor to function correctly. Using the formula below, we will choose values for L and C to be 1 mH and 22 nF respectively. This will place the resonance frequency at 33.932 kHz.

$$f_0 = 1/(2*\pi*\sqrt{L*C})$$

The amplitude detected by our sensor tank circuit is expected to be relatively small (~100 mV) from a short distance away from the wire. In order to amplify this signal to a proper voltage for our use, we will use the popular LM324 Op-Amp. The figure below is taken from the datasheet of the LM324. We will amplify our signal by 100 in a non-inverting op amp circuit. We are aiming to get the sensor within 4 inches of the perimeter wire for proper detection.

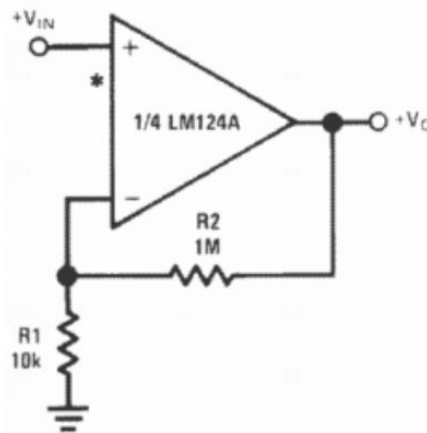

Figure 58: Op Amp Non-Inverting Amplifier

In order for the robot to be able to detect the perimeter wire in different orientations, it is appropriate to place various sensors around the edges of the robot. The more sensors the robot has, the easier it will detect the wire. Because

the LM324 is a quad op amp with four outputs, we will need to use two LM324's in this design. Each LC circuit will be hooked up to two back to back amplifier circuits, and there will be 4 LC circuits. RobotShop has a pre designed PCB that we will be using for reliability. The schematic and PCB are below:

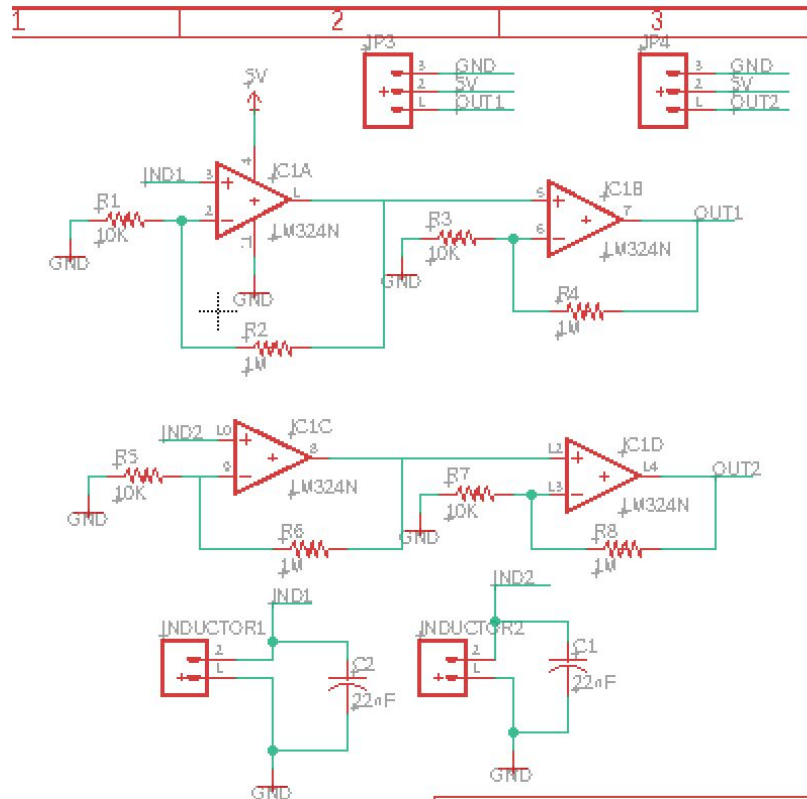

Figure 59: Sensor Schematic

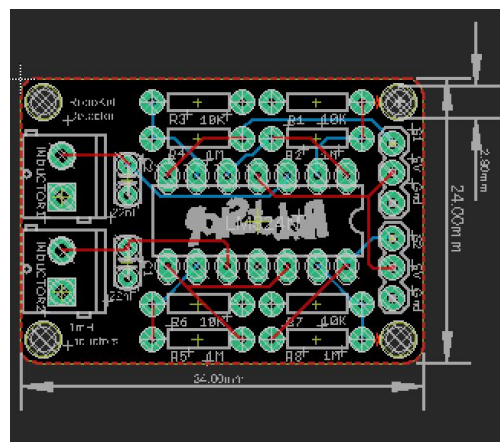

Figure 60: Sensor PCB

## 5.3 Breadboard Testing

In this section, we will discuss some of the testing that we began. It's important to run out breadboard tests and document early results. We will separately discuss each of the PCB board orders and test them respectively. This is a key learning step when carrying out any design for an entire system. It's crucial to verify correct, individual operation of components before integrating them into a whole system.

### 5.3.1 Wire Generator

As we can see in the oscilloscope screenshot below, the output of the generator circuit shows a rough square wave with a frequency of 36.62 kHz and an amplitude of 10.1 V. This amplitude was so high because a 10V power adapter was used. Our design lets us adjust R4 with a potentiometer. This adjustment can change the output frequency of the generator. This parameter is essential to have tuning because it is important that we match our sensor with the output signal so it can properly read it when we approach the perimeter wire.

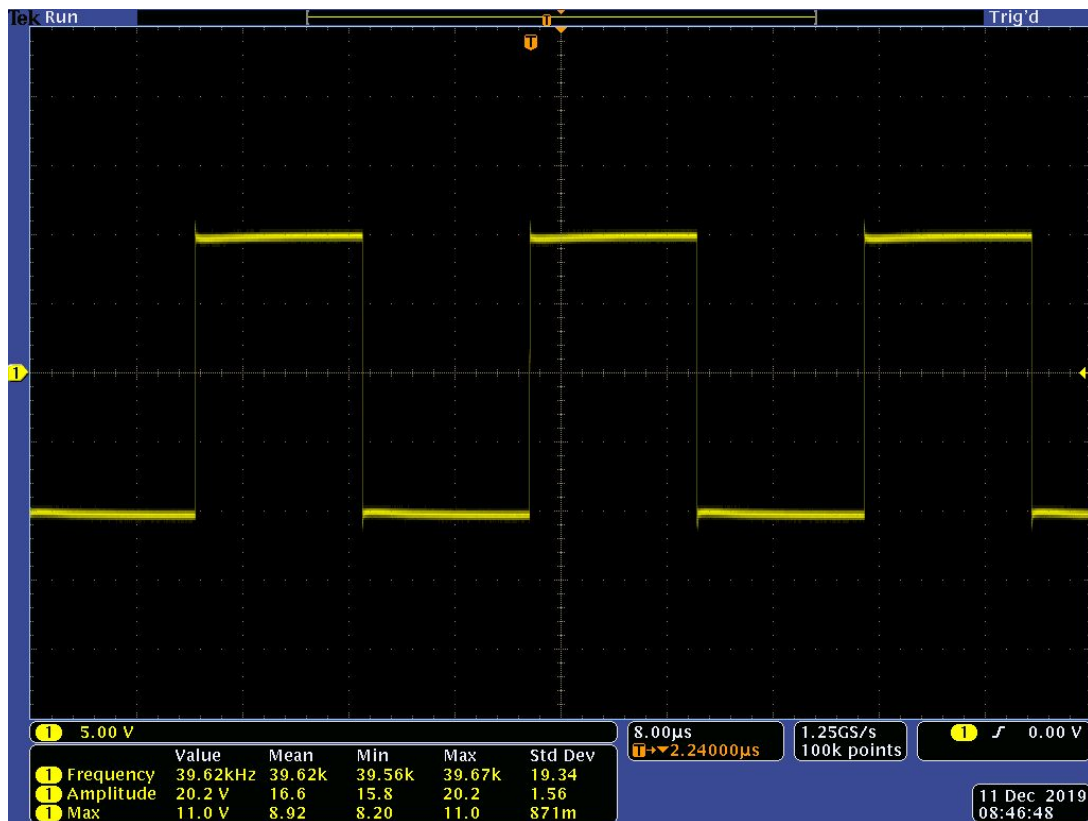

Figure 61: Generator Square Wave Output

### 5.3.2 Wire Sensor

In order to properly test our sensor, we have to test it with our wire generator. Ideally, the sensor will generate a waveform at its resonance frequency when it picks up the signal from the wire generator. The figures below are the tank circuit output and the output after the op amp amplification. These oscilloscope screenshots were taken, shown below, when the sensor was placed about 6 inches from the wire generator.

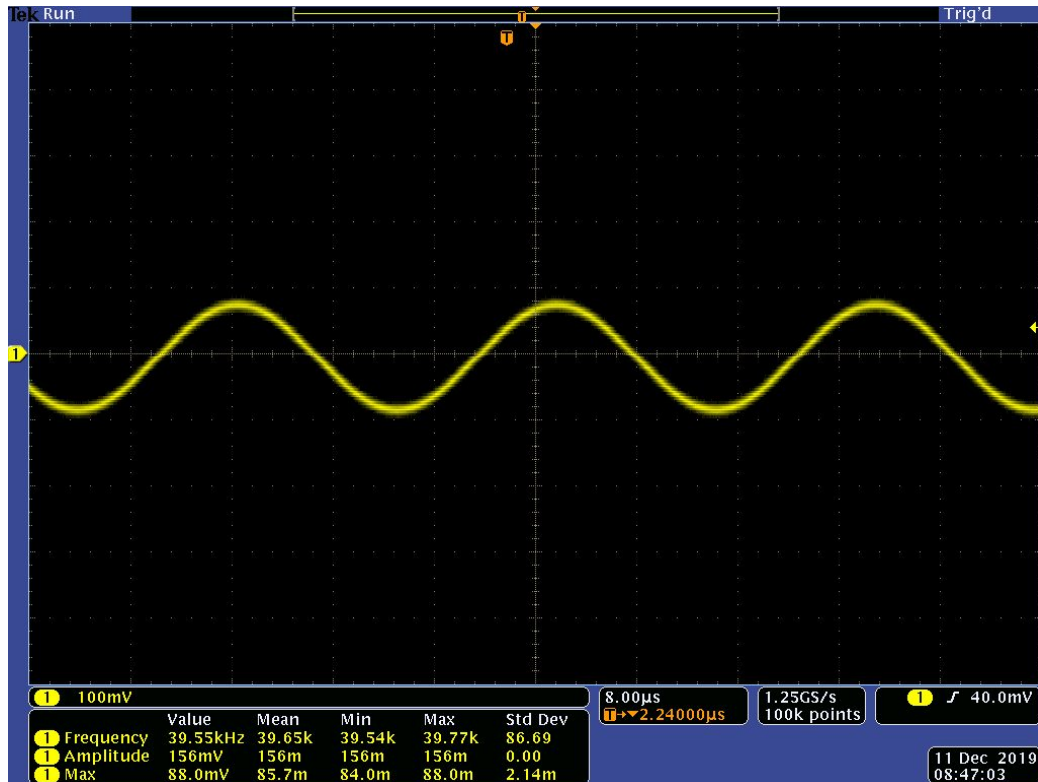

Figure 62: Tank Circuit Output

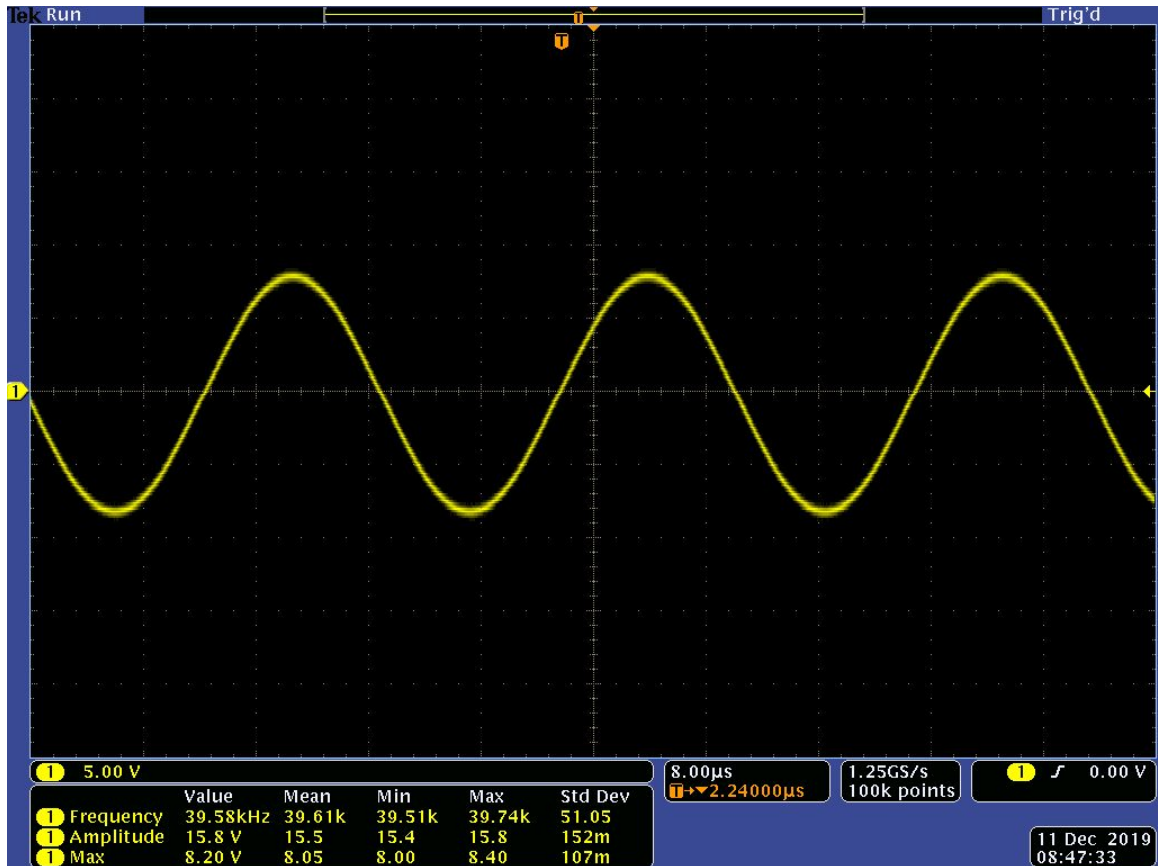

Figure 63: Tank Circuit Output with Amplification

## 5.4 Software Design

The approach taken for our software was to make our egoat as close to “plug and play” as possible. We did this by building a very basic working egoat using last years eGOAT and parts as well as a members breadboard, and arduino uno. The code was written in such a way that when the final morots are added it can be seamlessly plugged in without much coding being needed. This also applies to the other aspects of the robot. Once we the prototype eGOAT was made using an HC-SR04 ultrasonic sensor, though this is far different than the sensor we actually plan on using the use case is still the same. Once our three hundred sixty degree lidar arrives we will switch out the ultrasonic sensor for it and adjust the code accordingly. The base of the code currently is if something is seen in front of the eGOAT, reverse, and go around it, however once the lidar arrives it will be modified so that it will judge the distance more and as well as what is around it rather than right in front of it. If something is far away in front it’s okay to keep going but once it comes closer the arduino will be programmed to turn the egoat by stopping one wheel, whether that be the left or the right and have the

other keep driving, this will cause the egoat to turn one way or the other to have the egoat go around the object in front of it.

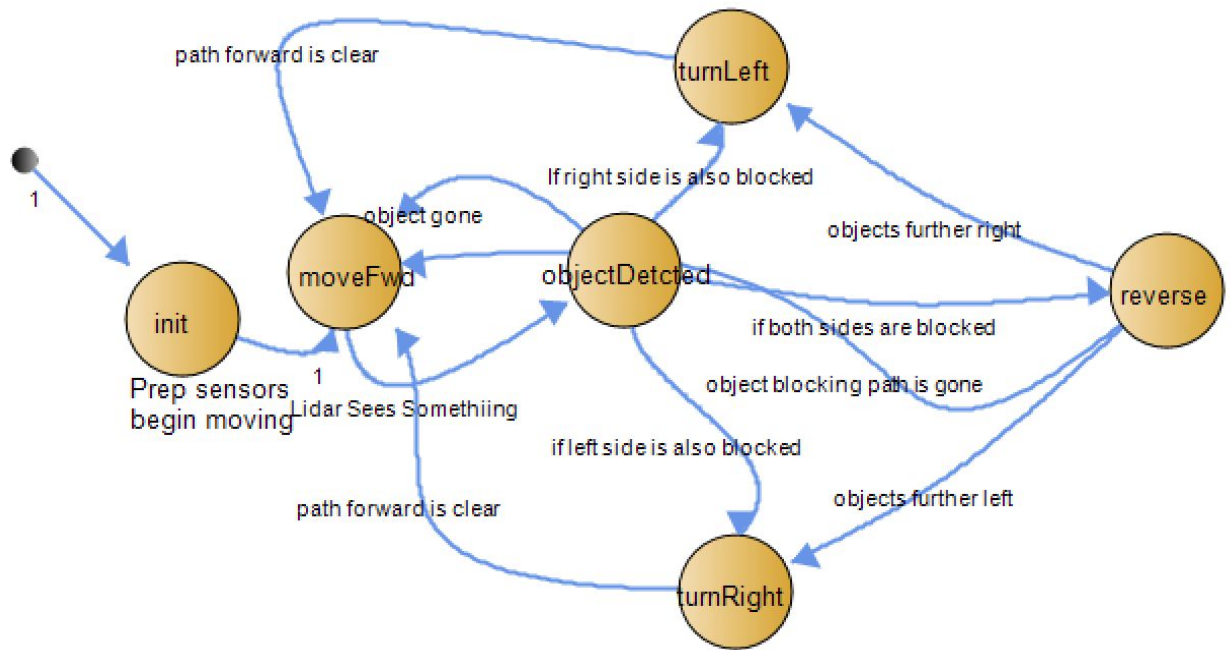

Figure 64: High level state diagram for eGOAT movement

### 5.4.1 Interface

The way the egoat should be built and operated there is no need for any sort of interface that the user would need to work with. This can be changed however depending on the feature set of the robot. If we make a remote kill switch and use a LoRa shield then that would open up the possibility for us to create a supporting mobile application that can be used in conjunction with the egoat. This application would have the ability to trigger the remote kill switch but depending on implementation we can also add the ability to summon the egoat to the user or have the egoat go to where it should be stored. This can work in a way that the user designates a spot as the egoats “home” and then there would be a clickable button that says “Go Home” and the egoat would turn off it’s grass cutters and go to it’s programmed “home”. On the software side this would take a large amount of time. Time is the biggest drawback to creating an application from scratch. Our group would have to sit down and decide if we should put in the time and development of it. Given our time frame it may not be beneficial to

build an application and have a user interface made. One other possible hurdle would be the accuracy of the GPS. If the GPS isn't accurate enough this could lead to a slew of issues happening with a "Go Home" feature or calling the egoat to user. The accuracy of the GPS is something that would have to be tested very thoroughly and would need to work one hundred percent of the time, otherwise there is no point in attempting to develop this application at all. Using this application as a kill switch however would be simple. It can send a signal to our arduino uno that will activate the kill switch and cut power to all the motors.

## 5.5 Mechanical Design

In order to develop a sense of direction for the design, a few rough calculations were made during the early stages of the project. Firstly, to begin outlining the strategy for cutting the grass as efficiently as possible, a minimum speed for the mower must be decided upon. By taking into account the area of the field, the time allotted, and the effective cutting width of the mower, the speed can be calculated:

$$\text{Mower Speed} = \frac{(\textit{Field Area})}{(\textit{Cutter Width}) \times (\textit{Time Allotted})}$$

Per the given information for the competition and assuming a maximum cutter width within the design constraints, the speed was calculated as follows:

$$\text{Mower Speed} = \frac{(50 \text{ ft}^2)}{(2 \text{ ft}) \times (15 \text{ min})} = 1.67 \text{ ft/min} = 0.0278 \text{ ft/s}$$

However, because the mower must turn to avoid obstacles and may return to areas previously cut, the actual speed for the mower must be faster than this minimum.

Next, for the selection of a suitable motor, the torque needed to begin moving the mower must be calculated. To this end, the moment of inertia the mower about the driving wheel must be ascertained. Because this rough calculation is only meant to aid in the selection of a motor, the geometry and mass of the mower are assumed to be such that the calculation yields the highest required torque. Ergo, the mower is assumed to be a hollow wooden box that completely fills the design space constraints, with one set of driving wheels located at the bottom on the sides. Using the formula for moment of inertia in conjunction with the Parallel Axis Theorem, the moment of inertia about the wheels can be calculated as follows:



$$I = \frac{1}{12}m(b^2 + h^2) + m\left(\frac{h}{2}\right)^2$$

Taking the mass of the box to be roughly  $m = 9$  kilograms, the base to be  $b = 0.61$  meters, and the height to be  $h = 0.51$  meters, the formula becomes:

$$I = \frac{1}{12}(9kg)((0.61m)^2 + (0.51m)^2) + (9kg)\left(\frac{0.51m}{2}\right)^2 = 1.059 \text{ kg} \cdot m^2$$

To calculate the angular acceleration of the wheel, the time taken to accelerate to the top speed must be decided upon. Assuming the top speed will be roughly twice the minimum speed, the angular velocity of the wheel can be calculated via this simple formula:

$$\omega = \frac{v}{r} = \frac{0.6 \text{ in/s}}{3 \text{ in}} = 0.2 \text{ rad/s}$$

The time taken to reach this speed is arbitrary, but for the purposes of this rough calculation, it will be assumed to be half a second. Thus, the angular acceleration is simply the angular velocity divided by the time to reach that velocity:

$$\alpha = \frac{\omega}{t} = \frac{0.2 \text{ rad/s}}{0.5 \text{ sec}} = 0.4 \text{ rad/s}^2$$

Finally, to calculate the torque needed to achieve this acceleration, the angular acceleration need simply to be multiplied by the moment of inertia:

$$\tau = I\alpha = (1.059 \text{ kg} \cdot m^2)(0.4 \text{ rad/s}^2) = 0.424 \text{ N} \cdot m$$

Because the actual mower will have two identical motors responsible for locomotion, the torque requirements for each motor is effectively half of the calculated value, somewhere in the magnitude of 0.21 Newton-meters.

## 5.6 Visual Design

After considering the competition requirements and guidelines, it was decided to design a robot with four wheels chained together to provide four wheel drive, three cutters, two in the front and one in the back middle, and using multiple sensors including LiDAR and ultrasonic for sensor detection. The final CAD model and exploded view of the pieces are shown below.

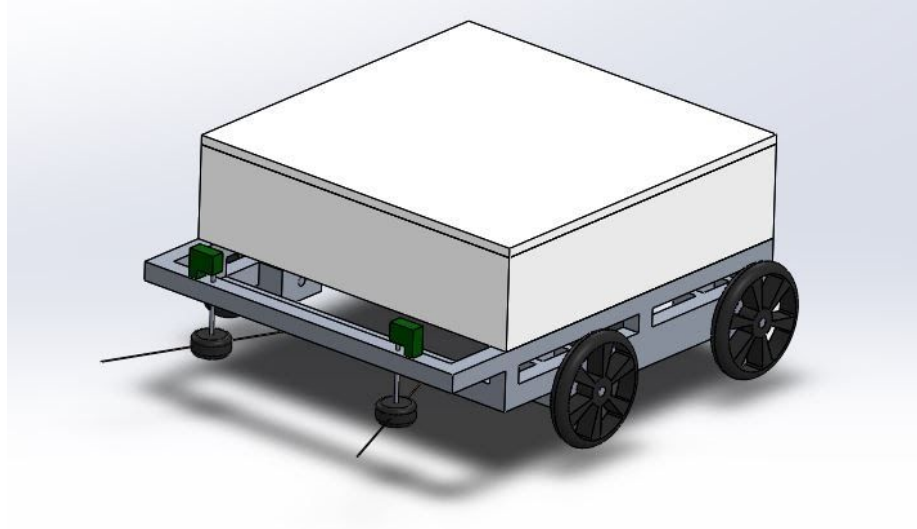

Figure 65: Isometric View

The main frame of the robot is made of aluminum, a strong but lightweight metal. There is a bottom frame that supports the wheels and axles, and a top frame that supports the cutters. On top of the frame is the housing that will hold the electronics and wiring. The two cutters in the front have a 12 inch diameter, allowing them to cut the entire width of the robot. The back cutter is to clean up anything that the front cutters miss, and to cut grass under the robot while the robot turns. The chain between the wheels provides four wheel drive to ensure the robot does not get stuck while traversing uneven terrain. The housing has a lid that can be opened for easy access to the electronics.

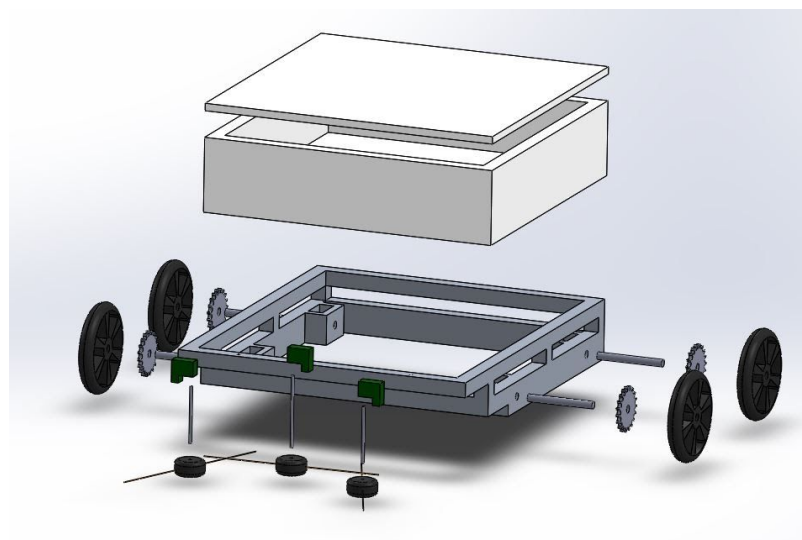

Figure 66: Exploded View

There are many problems we identified that brought us to this final design. After attending the site visit, it was noticed that the terrain where the robot is cutting is very uneven. This led to the design having four wheels instead of a swivel wheel, which would easily misalign itself in the rough terrain. It was also decided to chain the wheels together to have four wheel drive so all wheels keep driving even if one gets stuck in a small divot. This should make traversing the terrain much easier. Another issue is the need to cut efficiently. For this, a back center cutter was added to clean up anything the front cutters may miss, and also to continue cutting underneath the robot when it is turning.

One of the main issues that could hinder implementation of our design is protecting the wiring coming from our front two cutters. In the design, the front cutters are extended out in front of the robot to allow for a larger surface area to be cut at once. However, the downside to this is that the wires from these cutters will be exposed. We will need to cover them until they reach the housing to ensure protection. Along with this, the double frame of the robot will make it much heavier than normal. This will add strain to the motors and will need to be monitored.

## **5.7 Summary of Design**

The hardware design for the eGOAT consists of batteries, controllers, motors, perimeter wire generator and the sensor for the perimeter wire. The biggest design task was creating our generator wire and generator wire sensor. Most perimeter wires can be pricey and most GPS perimeter wires can be tedious for exact coordinates. The best route was to design our own. In addition, we were tasked with designing a few step down voltage regulators. This was essential to the design because it helps minimize battery usage. This is important for increasing battery capacity for all components. The reason we chose a step down voltage vs a step up voltage from a smaller battery is because of the reliability. Stepping up voltage can be inefficient due to the fact of device creating energy. Another plus of using one large battery to power multiple devices is the fact that only one power source will be drained but it will be in sync with the current draws of all the hardware electronics that it is feeding. If two batteries were used instead of one, they would need to have the same capacity and need to discharge at the same rate, which can be hard to implement. Overall, we will have 2 batteries: one to power motors and electronics and another backup battery for the beacon.

After power management, the next important topic of our eGOAT is the remote kill switch. This switch was implemented using radio transmitters. This could be

considered one of the most important parts of the project. Our design consists of two safety kill switches. One will be present on top of the robot. If you are in the range of the eGOAT and notice it isn't operating properly, there is a large button there. This is a kill all switch and will terminate power driven to all components of the system. Furthermore, a second safety kill switch is required. This requirement takes care of the case where the machine is too dangerous to approach. In this case, our separate remote controller can be used to cut the power via another large, red button.

The eGOAT will consist of an additional two PCB boards aside from the voltage regulator. The other two boards were used to create a generator wire and a sensor to detect the wires signal. This main purpose of this design was to ensure there is a back up safety precaution. The generator circuit uses a 555 timer to create a square wave in the range of 32 kHz to 44 kHz. There is a potentiometer attached in this design to ensure the generated signal can match the sensor's resonance frequency. The sensor uses an LC tank circuit with a designed resonance frequency of around 34 kHz. As long as the generator wire creates a signal with a frequency around that of the LC circuit, the LC circuit can resonate this frequency and interrupt our eGOAT. The interrupt contains the information that the robot is reaching the edge of the zone.

Lastly, the drive motor controllers and the trimmer motor controllers were selected to be external to the designed PCB's. We decided this would be most efficient when hooking up the system entirely. In addition, the suggestion for the design was to use "off the shelf" motor trimmers and drive motors. This suggestion was used and made our interconnectivity of everything simpler. Our design ensures a safe and very sturdy soldered connection that will not introduce any voltage drop or errors in the voltage signals being provided. A positive aspect of our design is that it is manageable when creating the final layout. The position and location of every component will have easy access and will be easy to differentiate. Our final design of our components diagram is shown below.

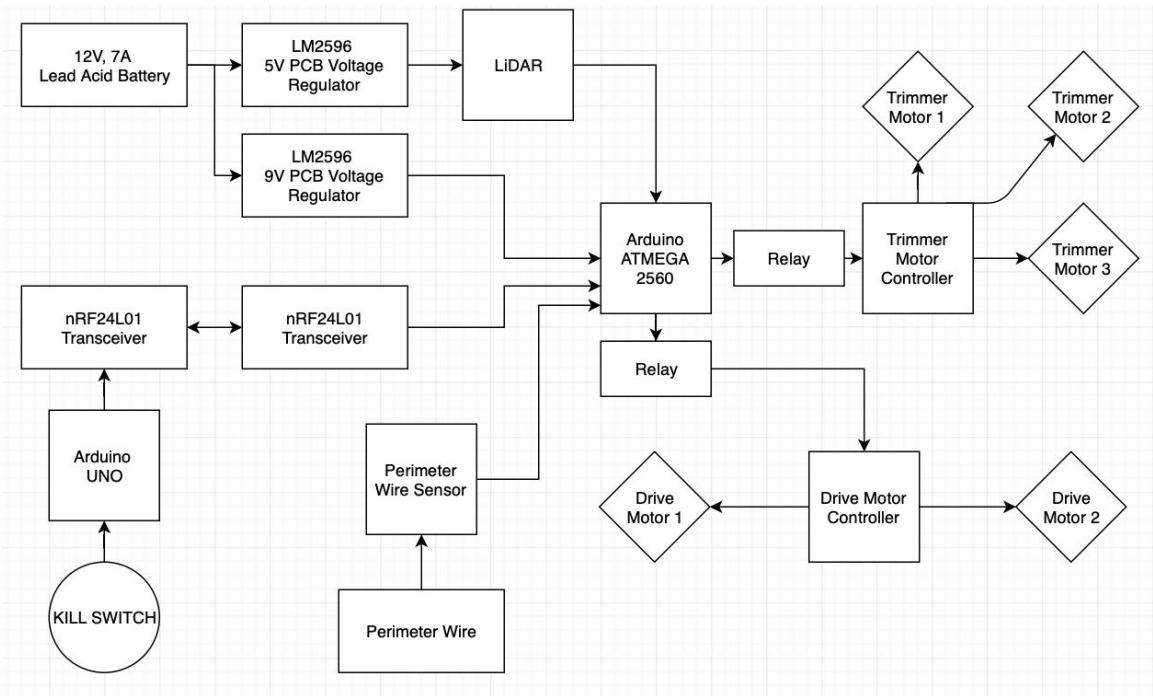

Figure 67: Final Block Diagram

## **6.0 Project Prototype Construction and Coding**

It is imperative in a system design to be able to validate that all separate sections and subsections are working up to their expected standard. If a single section isn't functioning properly it is also important to be able to identify which part it is. In order to have a cohesive system integration and testing must be established clearly and be administered thoroughly. Every component down to the resistors and capacitors have to be properly tested. Once the correct function is verified, the subsystems must be tested as well in order to verify it was designed correctly. Finally, when every subsystem is taken into account then the system as a whole will be tested. After this testing and integration happens, the final product will be developed. The challenge of integration is finalizing the idea into a perfect product. Connecting each subsystem brings forward questions that goes unseen during the design. This chapter will discuss different things that go into combining everything into one system.

### **6.1 Integration**

In a nutshell, integration can be split into two different groups: power connections and dataline connections. When it comes to hardware, device ports need to be properly connected so the device can receive and send information the way it wants. From a software point of view, the program integration is more of a transfer of information from component to component. It's important that the arduino receives the information properly. If this isn't correct, it won't be possible to send commands without data received. Without reiterating too much on the communication protocol, the later sections will go over a high level review of these fields in a different way.

### **6.2 PCB Design and Considerations**

A Printed Circuit Board (PCB) is a board that electrically connected components using conductive tracking through the use of copper laminated sheets in order to supply power through a system. PCB is the most common way to connect electrical equipment in today's market because it is cheaper and production is able to be automated. PCB's can require additional design then compared to past techniques such as wire wrapping but current Computer Aided Design (CAD) software can help offset the additional work. A PCB is created by a layer or layers of copper tracks that are laminated onto sheets of insulating sheets. The copper tracks can have multiple layers in order to allow more connections in a smaller area. The connections can not cross so multiple layers can prevent the

circuit being short circuited. The two most common way in mounting components to a PCB is through “Surface Mounting” and “Through Hole”. Through hole components are mounted by first passing wires through the board where they are then soldered and the tips above the soldered can be clipped. Surface mounting is done by attaching the leads directly to the copper traces on the board. Both these techniques can be implemented on a PCB at the same time and are use for particular components. Surface mounting is commonly used for smaller components like resistors, diodes and through hole is traditionally used for larger components such as large capacitors.

## **6.2.1 PCB Composition**

PCB are comprised of multiple layers, there are 4 distinct layers when looking at the composition of a single copper layer and they are stacked on top of each other like a cake. Starting from the top layer to the center is the silkscreen, Soldermask, Copper and the substrate. There are multiple layers to a PCB but they are still very thin, for example the common thickness of a PCB for an arduino is only 1.6mm.

### **6.2.1.1 Copper Layer**

The copper layer is used to actual make the connections between components and is able to come in multiple layers, it is possible to have 16 or more layers. The copper layer is laminated to the board through the application of heat and adhesive. In lower cost electronic gadgets it is common to see the PCB have only only one layer and when double sided is mention in PCB’s it means it is a 2-layered board. The amount of layers needed is dependent on how many connections are being made in a set amount of real estate on the board. The amount of copper that is traditionally used in a PCB is 1 ounce per sqft on a PCB but is possible to raise that higher if the board is being designed for high power applications.

### **6.2.1.2 Silkscreen Layer**

The silkscreen is the very top layer of a PCB and is used to help the locations of the components on a PCB. The labels allow for easier setup when soldering the material and an easier understanding of the board. Common applications of a silkscreens can be seen on developmental boards that label multiple inputs and outputs such as buttons and LEDs.

### **6.2.1.3 Solder Mask Layer**

The Solder Mask is the layer above the copper foil and is traditionally colored green but it is possible for it to be multiple colors. The purpose of the Solder Mask is to insulate the connections of the copper layer when solder is being applied. The mask prevents accidental connections with other metals and helps the user solder the correct points. The mask does not cover up the small traces where components are supposed to be surface mounted.

### **6.2.1.4 Substrate Layer**

The Substrate of a PCB is the base material used at its center. The Substrate is important because it does not only provide the strength of the material but also controls its dielectric constant and determines how fire retardant the PCB is. A very common substrate that is used is FR-4 which “FR” actually stand for flame retardant. FR-4 is a glass-reinforced epoxy laminate that is popular because of its capabilities that allow it to be used in multiple environments. FR-4 has a good strength to weight ratio and is capable of being used in both mechanical and electrical applications in both humid and dry environments. The capabilities of FR-4 make it a good consideration to be used on the eGOAT as its substrate due to its flexibility to be used in most environments.

## **6.2.2 PCB Vendor**

Choosing a PCB Vendor is a task that will have to be taken with the utmost care. The PCB will be a major component for our circuit board design and a vendor that has a reliable reputation in addition to having a reasonable price will be what we are looking towards. As we continue with our planning and create a more concrete design, we will be determining who to order from.

Choosing a vendor to construct our design onto a PCB is a careful consideration. They must have a great, reliable reputation as well as above acceptable quality products that can be produced within a timely manner and at reasonable cost. Keeping this in mind, the PCB vendor that will take on designing our board will be OSH Park. We believe that they are a reputable choice because of our own experience with using them to create extracurricular PCB designs. With the outstanding production of these extracurricular boards, we knew that we could entrust OSH Park to design our boards for our project.



The prices for producing PCBs from OSH Park are as follows:

- The Standard 2 Layer Order - \$5 per square inch
  - Includes three copies of the design; order is in multiples of three
  - Ships within 12 calendar days
  - Board Thickness: 63mill (1.6mm)
  - Copper Weight: 1 oz
- The Standard 4 Layer Order - \$10 per square inch
  - Includes three copies of the design; order is in multiples of three
  - Ships within 2-3 Weeks
  - Board Thickness: 63mill (1.6mm)
  - Copper Weight: 1 oz (outer), 0.5 oz (inner)

\*OSH Park does give the option for Super Swift Service for the Standard 2 Layer boards at a price for \$89 extra. This would have the boards shipped within 5 business days opposed to the standard 12 calendar days. Otherwise, all shipping cost would be \$0 unless opted for sooner delivery time at expedient rates.

Specifications:

- All 2 layer boards are FR4 170Tg/290Td which are suitable for lead-free processes and temperature
- 4 Layer boards are now FR408 (180Tg)
- They have ENIG (gold) finish for superior solderability and environmental resistance
- They're 1.6mm thick (0.063 inches) with 1 ounce copper on both sides. For four layer boards, the internal copper is 0.5 ounce
- The minimum specs for 2 layer orders are 6 mil traces with 6 mil spacing, and 13 mil drills with 7 mil annular rings
- The minimum specs for 4 layer orders are 5 mil traces with 5 mil spacing, and 10 mil drills with 4 mil annular rings
- Internal cutouts are allowed and supported. Draw them on your board outline layer
- Plated slots aren't supported

Assembly of the boards will require us to solder on the boards with the electrical components that we designed in the schematics. We will personally piece the components on the board since we have personal experience with soldering from extracurricular projects and on-the-job experience through internships. All PCBs will be connected using connector cables that we will design ourselves.

### **6.2.3 PCB Assembly**

A computer simulation tool will be used to make a PCB layout on a program like SPICE or OrCAD. This will help us verify our circuit design and prototype it. This helps catch errors in the circuit instead of wasting valuable time in the lab. It is a nice tip leave some holes at some pins incase you have to make some patching to fix a small bug in the circuit. Once the board is tested and you confirm that the errors on the program are okay, you can send the schematic to be printed out and sent to you.

## **6.3 Final Coding Plan**

The final coding plan will involve making a code for our prototype so we have a baseline, then as parts are added in, changed, or taken away the code will be modified. As discussed we want our code to be similar to be plug and play in a sense. Having code set up this way will make swapping parts and taking components in and out easier on the programming side. As parts are added our we will create functions to use these new parts and make them easily readable and adjustable for future users and/or future students to modify. If a part is taken away it will be simple to find where in the program that part is being used and remove it if needed. Testing of the code is described below but will be done in pats to ensure each part of the egoat is working as intended when it is being added to our build.

## **6.4 Project Prototype Testing Plan**

Our egoat project will go through many different prototypes and but will generally be tested in a grass field. The texture and feel of the grass field may vary from location to location however as the place of test for the first prototype has very thing grass where you can see the dirt. If tested at UCF it would be a more full grass field as compared to our first environment. We will also test the egoat on asphalt and cement to ensure that it can drive safely on any plain. We will have other ideas of testing to best ensure our egoat is function properly.

### **6.4.1 Hardware Test Environment**

The hardware testing environment will be different depending on the hardware. For wheels the grass, dirt, cement, and asphalt will be best to ensure that our wheels will maneuver well on any terrain but most specifically dirt and grass.

Sensors will be tested on inanimate objects such as trash cans, trees, buildings, and balls. The egoats sensors will also be test with us standing in front of it, for

these kinds of tests it doesn't really matter where we are. The environment for this testing will be more controlled.

## 6.4.2 Hardware Specific Testing

All hardware will be tested and examined when received or made to ensure nothing is damaged and it works properly. What this means is that for each individual piece of hardware we will have set tests.

For the wheel the tests will be usable and stable on different terrain. If a wheel doesn't work in damp grass for instance than we know this wheel is no good, let's get a wheel with better grip.

Testing the wheels and motors of the prototype egoat that we built using last year's egoat's parts we first tested indoors in a controlled environment where the motors were powered by a power supply and the wheels were elevated as to not mess up the workspace while when they began rotating. In First testing when it was just one motor we found that the polarity on the relays was important and made sure to note down which wire of the wheel would result in a counterclockwise rotation when a voltage was applied and which wire resulted in a clockwise rotation when a voltage was applied. From there we tested the two motor wheels together and decided to change our way of thinking from counterclockwise and clockwise to simply forward and reverse because the wheels being on the opposite sides meant that going forward had one wheel rotating clockwise and the other rotating counter clockwise in reference to one another, changing our way of thinking about this rotation was a better move for our group. After successfully testing on the power supply and macbook we decided to test the full robot with its ultrasonic sensor outdoors. When taken outdoors however it didn't move. After some debugging and checking the wiring we found that the wheels were placed into the wrong relays. Instead of one wheel motor being on relays one and two then the other being on relay three and four, we had one wheel motor on one and three with the other being on two and four. This happened because we had to disconnect the wheel motors from the relays to refit the wheel motors into the chassis of the old robot. It was good for testing as now we know for future use that we need to ensure our wire polarity for the wheel motors is plugged in correctly. Once we got this fixed the Egoat was taken back outside and it worked. We found two big issues thought and that was that the wheels and motor system used for last year's project was insufficient. The wheels could easily get stuck on the egoat itself as the wheels had nothing to keep them in one steady place. Aside from this last years Egoat used a swivel wheels and this was very unreliable. It would cause the egoat to to turn unnecessarily if the egoat were reversing and on software ground the swivel could get stuck in a sideways position. With this in mind, the group decided to go

with a 4 wheels design where still only 2 wheels are controlled but the two wheels on each side would have a chain between them and work like a bicycle chain. This was good testing that helped us decide that we need a better design for wheels and that we can't reuse last years design.

For testing the new wheels and motor when they are first received we will use a power supply to ensure that they are correctly receiving power. We will push more voltage to ensure that higher voltages speed it up and lower slow it down. If we flip the polarity the motor should spin in the opposite direction of when originally tested. This testing would ensure that our motors are working electronically and that it has the capability to allow our egoat to go in reverse.



Figure 68: Power supply testing that old wheel motors work correctly

Batteries will be tested by having it power either the motor or the arduino depending on the batteries voltage. This will ensure that the battery in question is working as intended if it is able to successfully power either the motors or the arduino. We tested last years egoats main battery by having it power both of the grass cutting motors, and the wheel motors

The housing of the egoat will first be tested separately with without any electronics plugged to it. This test will involve some basic durability tests to

ensure the structure doesn't break if an accident were to occur or during normal operation of the Egoat. This durability test could include lightly hitting it with a ball or putting weight on it. Structural integrity will be important for the Egoat. Florida is a state notorious for its unpredictable weather so we will also ensure that it will be able to withstand water. We can do this by simply dumping water on top and seeing if there is any sort of major leaks on the inside. These tests will ensure the egoat will be running and okay if any accidents or factor outside of our control were to occur.

We will test the grass cutting mowers first independently before plugging it into the Egoat. This will be done by hooking the mowers up to our battery to ensure that the mowers are taking enough voltage to spin at a high enough RPM to cut grass at a stable rate. This testing will help prevent us from having to take the robot apart later if we were to ever find that the egoat isn't cutting grass properly. We did this testing with the original motors of last years Egoat and found that even though they work. We first powered them with a power supply to ensure that the grass cutter mowers were still working properly. We then power them on with a battery to ensure the battery was working properly and could power the grass cutting motors. Finally we took the grass cutting mowers outside with one a PWM motor controller and found that both the PWM motor controller and the grass cutter mower worked and we were able to successfully cut grass. Despite the test showing positive results however we have decided to go a different route with the grass cutting motors and keep these as a backup in case we find a better use for them.

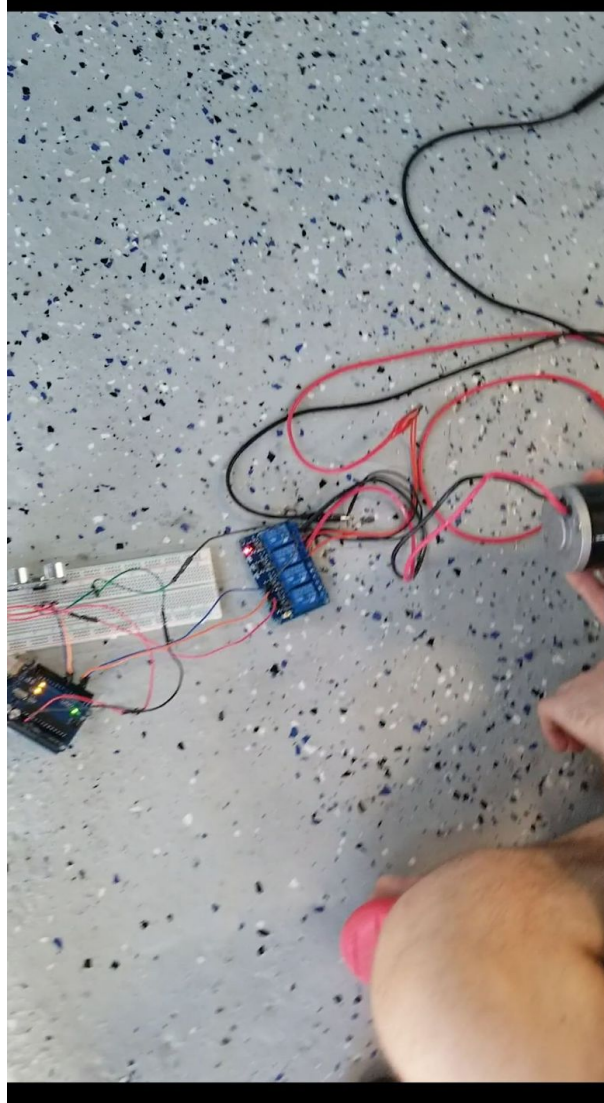

Figure 69: ultrasonic sensor integrated with wheel motor testing

The old Egoat had two PWM Motor control boards that we took to the side to test. We powered it using the power supply and found that both boards were working correctly for controlling the speed of the motors. We thought about using these to control the RPM of the wheel motors but unfortunately weren't able to use it this way because they didn't have two outputs only one and to use with the arduino and not the knob that comes attached to the boards, they would need to be modified.



Figure 70: Alphagoat movement testing





Figure 71: alphagoat getting stuck because swivel wheel

### 6.4.3 Software Test Environment

Software will be written and verified on a macbook pro running macOS 10.15 within the Arduino software. It will be deployed to the arduino being powered by



the macbook and will be tested on the spot to ensure the software is working correctly.

#### **6.4.4 Software Specific Testing**

When testing the software this will first involve testing with our hands. What I mean by this is we will suspend the egoat in the air and push the code to the arduino and power the arduino with the macbook. The reason for this is because when powered by the macbook we view the serial monitor to ensure that we are getting our expected output from the arduino.

When using the ultrasonic sensor and testing to ensure the software programmed for it is working correctly, we first had the arduino and the ultrasonic plugged along with the wheels disconnected. We ensured that the ultrasonic sensor was reading in distances by waving our hands in front of the sensor at different lengths away from the sensor. With the arduino software we opened up the serial monitor and ensured that the distances reflected how far our hands were.

Software testing the wheel motors started one at a time. The motor received power from a power supply and was plugged to a relay while the arduino received power from the macbook. The wheel was suspended in the air as not to affect the workspace once the wheel starts rotating. The software was first written as the motor going clockwise and counterclockwise. If nothing was directly in front of the ultrasonic sensor then the motor would spin clockwise, once something came within 20 cm of the ultrasonic sensor the motor would spin counter clockwise. In doing this testing we learned about the polarity of the wheels and flipped what we considered was clockwise and counterclockwise. We found however that the ultrasonic sensor was working correctly and the motors were rotating in certain directions based on the readings of the ultrasonic sensor.

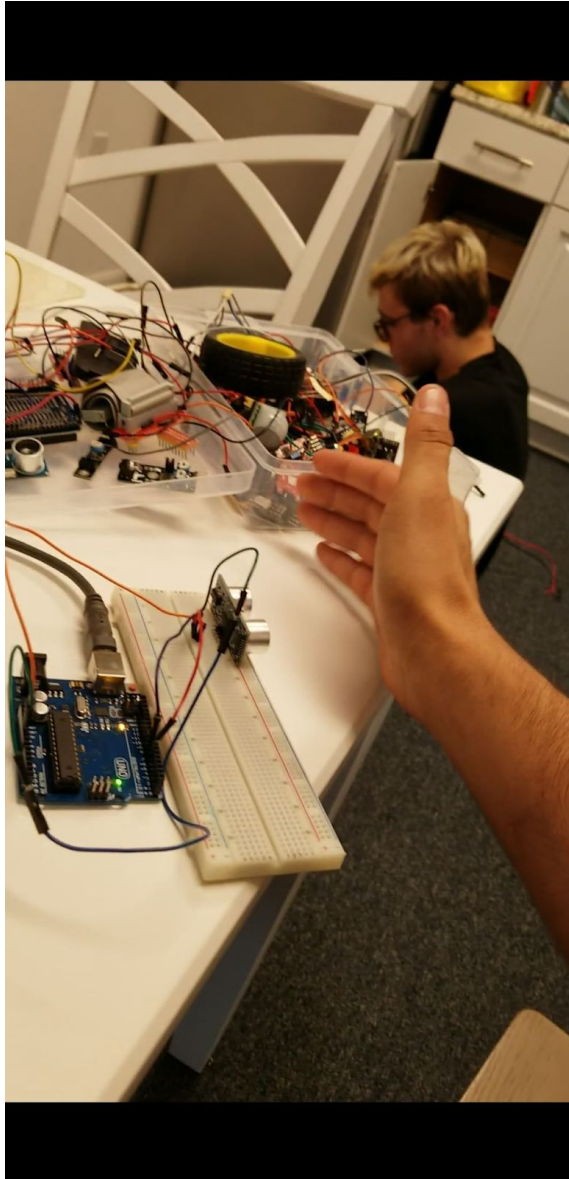

Figure 72: Ultrasonic sensor hand testing

When we decided to test the software with both wheels, we had both plugged to relays and the code was altered to include the second wheel. We accounted for the fact that the wheels could no longer be looked at as clockwise or counter clockwise because the wheels would be on opposite sides so their reference would be opposite of each other. Instead we changed to a forward and reverse motion. So if there was an object directly in front of the ultrasonic sensor, then both wheels would go in reverse. If nothing was in front of the sensor then the wheels would go forward. In this testing we ensured out polarity was right and were able to ensure that we had control of both motors. After testing with our hand we took the robot outside to test it outside and see how it functioned. The

software functioned but we found that it could function better. A delay had been placed in case of a reverse because at this point the egoat in moved forward and back. There was no limit to how far back the egoat would move so we used a delay to have it move back for just over 1 second. The arduino isn't programmed with interrupts yet however so having this delay in the infinite loop made the egoat seem like it didn't respond correctly to an object being in front of it. Once this delay way removed it worked seamlessly.

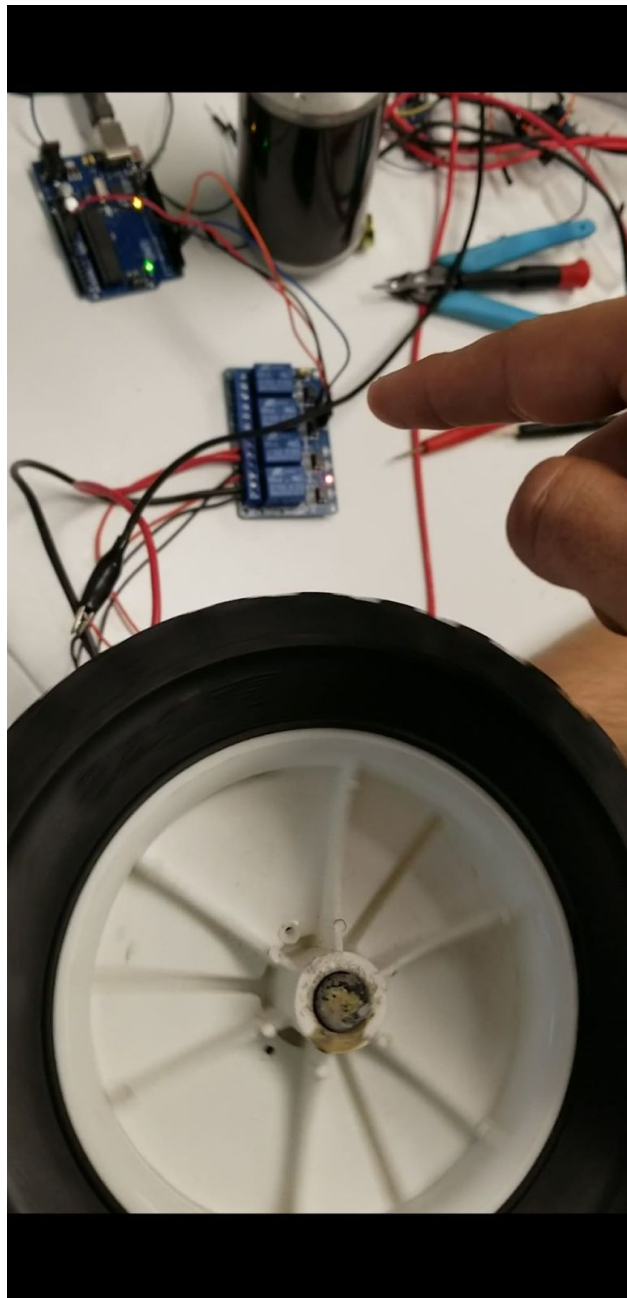

Figure 73: Wheel motor testing with relay

Once the new wheels and motors are acquired we will take the old ones off and put the new ones. As the way we designed the code it should be plug and play with maybe only a slight modification being needed for the code if any. We would like to look into testing if there is a way the PWM motor controller boards could be interfaced with the arduino so that the arduino could control the wheel motors RPM's but this would require modifying the PCB board and having to find a way to get it output to two sources. The software for this will be tested later if we decide to go down this route.

The lidar will be the most software intensive piece to test. The lidar will be tested in the same manner as the ultrasonic sensor. When hooked up we will first ensure that it is reading distances properly by hand. The arduino will be plugged in and powered by the macbook so that we can read the outputs of the lidar from them serial monitor.

When the final wheels and lidar are together we will test how well our software can integrate them together by having the lidar detect objects at different angles it can view and if there is something there have the egoat evade the object by different means. We will account for the lidar being able to detect the sides and program the arduino to handle objects on the sides better to result in a better obstacle avoidance system. This obstacle avoidance system will involve the lidar seeing an object and having the egoat maintain a minimum distance away from the object. This will require that the egoat be able to handle it's speed and turning well. We will need to test the radius of the turning before and if possible interface the PWM motor controllers with the arduino and the relays to help better control the egoat. If we could have the egoat slow down as it gets closer to an object head on that would be extremely beneficial to the egoats overall maneuverability. The lidar would also improve the egoats foresight. If an obstacle was straight ahead, the egoat would be programmed to read both the right and left side to see which path it should take. As a result of the lidar being a full three hundred sixty degree sensor that rapidly scans its surroundings it would be easy to ascertain which path the egoat should pursue. These tests will help ensure that our egoat is prepared for any obstacle. We will best be able to test our lidar sensor outside with the trees and other random objects we can put in its way to ensure it can safely travel and maneuver around the terrain.

The egoat must feature a remote kill switch that can be triggered anytime. Testing this will be fairly straight forward. The arduino can be programmed with an interrupt and push button. When the push button is pressed I will break out of the infinite loop and have the arduino cut power to all motors, this includes the wheel motors and the grass cutter mowers. The good thing about implementing a kill switch in this manner is that the kill switch can be safely tested and the egoat

can be reused. I would describe this more as an off button as opposed to a kill switch.

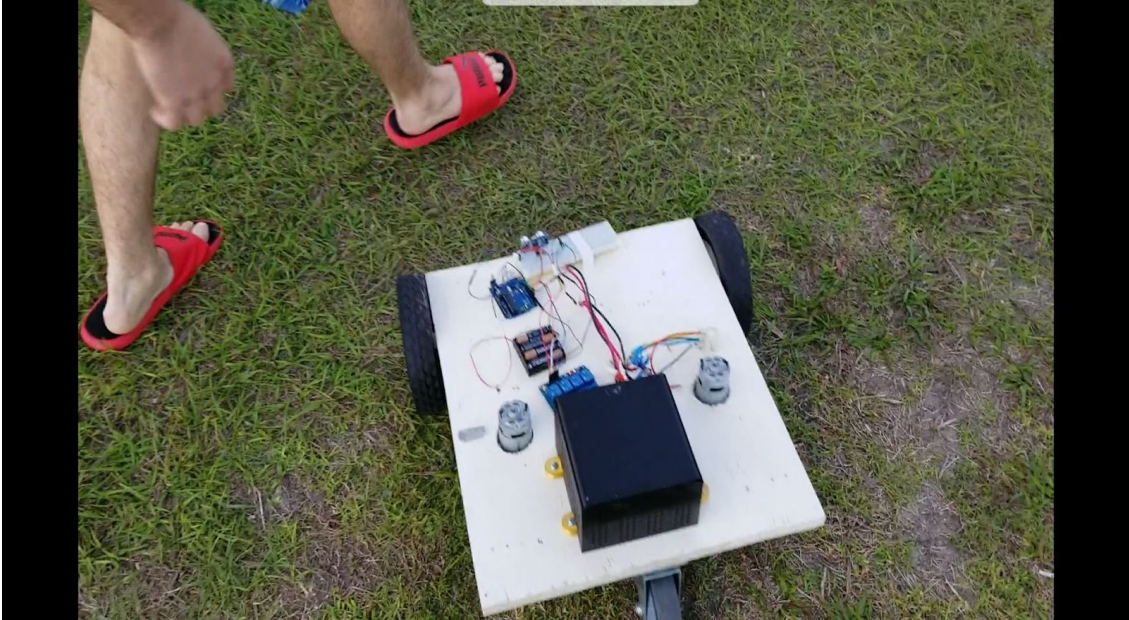

Figure 74: Obstacle avoidance testing

# 7.0 Administrative Content

This section of the report will be discussing some, or all, of the aspects that will determine how well our team will spend budgeting their time as well as expenses. The budget will be determined by our sponsors and will be discussed in a later subsection.

## 7.1 Milestone Discussion

This section will break down what it is we as a group, as well as individually, will be working on. Factoring in estimated and actual starting dates as well as estimated finish date and any milestones that are already completed. More shall be added as the days and weeks continue and a more concrete schedule comes into place, the Gantt chart, **Figure 75**, will cover from the first weeks of senior design in Fall 2019, and will give an estimated timeframe as to what will happen and our hopeful progress up until the end of the 2020 Spring semester when we will our presentation at the end of Senior Design 2.

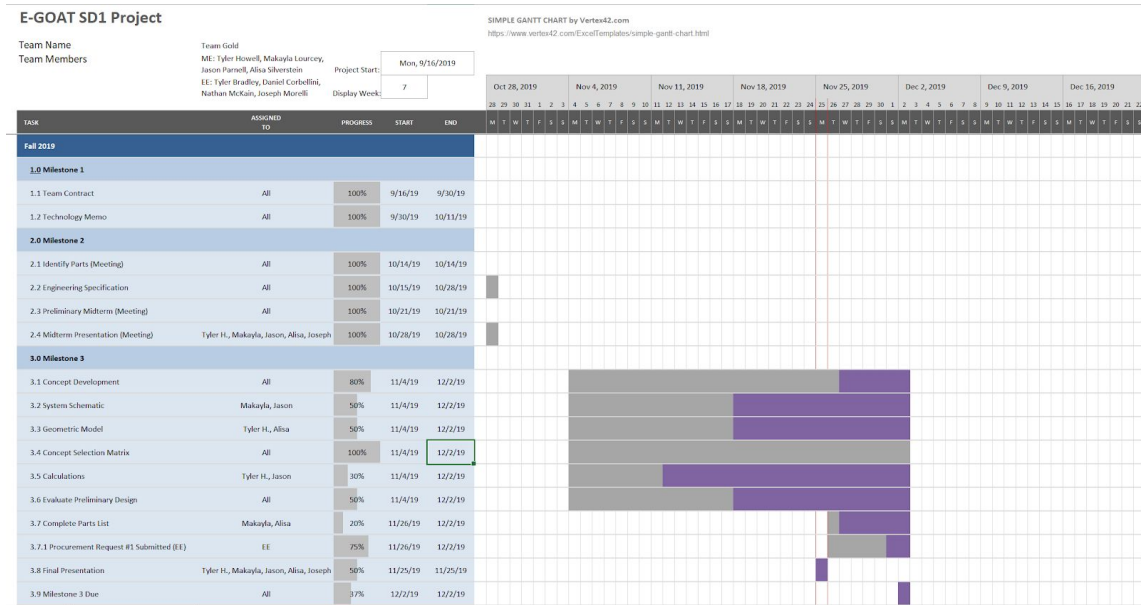

Figure 75 Gantt Chart

Number	Task	Start
Senior Design I		
1	Formation of Groups	8/28/19
2	Creation of Idea	9/2/19
3	Roles for Project	9/6/19
4	Initial Divide and Conquer	9/4/19
5	Updated Divide and Conquer	9/30/19
6	Power Supply	10/20/19
7	Microcontrollers	10/20/19
8	DC Motors	10/15/19
9	Doc. Review Meeting with Dr. Lei Wei	11/4/19
10	Order Parts	11/8/19
11	Final Document Due	12/2/19
Senior Design II		
12	Prototype Assembly	TBD
13	Testing and Redesign	TBD
14	Finalization of Prototype	TBD
15	Final Document	TBD
16	Final Presentation	TBD

**Table 4: Project Milestones**

<b>Date</b>	<b>Description</b>
August 31	Project selection, initial requirements received
September 20	Initial Divide and Conquer
September 25	Phone call meeting with clients to clarify requirements. Client gives advice on techniques and ideas
October 4	Divide and Conquer Rev2
October 18	Field visit to Solar Farm
November 1	60 Page Document
November 8	Receiver component decisions and specifications from Mechanical Engineer team
November 9	Complete an order form. Received instructions on how to order parts using department budget
November 10	Get OK to order parts
November 11	Second phone call meeting with client.
November 15	100 Page Document
November 27	First components begin to arrive. Still waiting on others as of December 4.
November 28	Begin initial breadboard testing
December 4th	Final Document

**Table 5: Senior Design 1 Detailed Timeline**

## **7.2 Budget and Finance Discussion**

Doing an interdisciplinary project means we will have greater budget than the average group. Our total system materials and assembly cost target is \$1500. We are looking at spending \$500 – \$700 on parts depending on the quality of



parts, where we buy them, and what features we really want. The main components we will be needing for the eGOAT are wheels, bearings, motors, either one or multiple batteries, LiDAR, camera, boards, and some other computer hardware. Our team will break down what we want and need while determining what is the most feasible purchase choices for our project. Our parts will be split amongst the groups in such a way that what we are buying pertains more to their respective specialization. We will also discuss our project budget continuously with our sponsors to ensure that we are building this project within our specified parameter and budget incase our budget needs are determined to be more than the allotted \$1500. The break down for some possible example parts and our minimum parameters for that part are as follows.

<b>Discipline</b>	<b>Component</b>	<b>Minimum Parameters</b>	<b>Bought Part</b>	<b>Cost</b>
Mechanical	Wheels	Drive Wheels: Drive Wheels: rubber, deep treads. Follower wheels: rubber or polyurethane, outdoor designated materials only	Shepherd Hardware 9610 6-Inch Semi-Pneumatic Rubber Replacement Tire, Plastic Wheel, 1-1/2-Inch Diamond Tread, 1/2-Inch Bore Offset	\$17.80
	Bearings	Stainless Steel, double sealed/outdoor use designated	XiKe 4 Pack Flanged Ball Bearings	\$14.99
	Motor	12V DC, 75 in-oz	Lynxmotion 12V 90rpm 99.11 in-oz 1:26.9 Brushed DC Gear Motor w/ encoder	\$70.40
			12V 80rpm 47.77 oz-in 1:26.9 Brushed DC Gear Motor w/Encoder	\$65.60
	Trimmer Head		Trimmer Head for Echo Speed Feed 400 SRM-225 SRM-230 SRM-210 Echo Weed Eater Pas210 Pas211 Pas225	\$43.96
Electrical	Battery	Ah rating allowing for 1 hour of runtime	12V 7A Lead Acid	\$35.50
			3.7V Li-ION	\$23.18
	Regulators		5V regulator	\$4.77
			Custom Output Regulator	\$2.31
	LiDar	10m range	RPLIDAR A1M8 - 360 Degree Laser Scanner Development Kit	\$99.00
Comp Sci.	Boards	2 GB RAM for primary boards (4 GB RAM recommended), Ethernet or Serial communications for all boards	Arduino Mega 2560	\$55.00
	Computer Hardware	Min 50 foot range	NEO-6M GPS	\$79.00
Adafruit RFM96W 433MHz LoRa Radio Transceiver			\$19.95	

### **Table 6: Budget**

As seen from the table there are possible ways to go when it comes to parts. They can become very expensive very quickly. The most notable part with a fluctuating price looks to be the battery. The battery could be \$107.95 or it could go as low as \$32.99, it is important for our group to take parts like this into consideration and think about what the more expensive one can do, or what does it offer that the cheaper one does or does not. We want good quality materials that will get the job done but we also want to ensure we aren't wasting money. When buying our parts we will always consider our minimum parameters first and foremost, then see what we have left from our budget to spend.

Keeping track of our expenses will be and is incredibly important, as the information will allow us to determine whether we have kept the design below the required price range, while also giving enough information for our sponsors, Orlando Utility Commissions and Duke Energy, so that they could have a say in whether any component in the prospective design is too expensive or cheap.

## 8.0 Conclusion

As of the date this document is submitted, the major achievements the project has accomplished include: the movement strategy for cutting the field's grass as efficiently as possible, the geometric placement of cutting motors and tires on the chassis of the mower, and the selection of major parts and materials for assembly.

Moving forward, the team has yet to develop a specific plan outlining the actual construction of the mower and chassis assembly. However, this obstacle will surely be overcome as the more minute aspects of the design are finalized. In particular, as more stress analysis is conducted upon the load-bearing parts of the mower chassis, more concrete fastener requirements will become apparent, further crystallizing the final design. Additionally, the project still requires a sufficient electrical-mechanical interface, allowing accessible circuit programming and smooth motor interaction. This portion of the design will be handled jointly by members of the Mechanical Team and members of the Electrical Team to ensure a proper arrangement suitable to the demands of the project.

## 8.1 Difficulties

Reflecting back through this semester shows that a lot of lessons were learned. Our team was composed of four Mechanical Engineers, three Electrical Engineers, and one Computer Engineer. It was the first large team oriented project that we were all apart so it was a learning experience for everyone. Some of the difficulties are as follows:

1. Interdisciplinary vs Non-Interdisciplinary: When we were first making a decision as a group, this was our first encounter. Some of the benefits that made us decide was: no out of pocket money, guidelines on how to build, and repetition of a previous project. However, this decision came with some disadvantages.
2. Ordering Process: There is a process to order parts when its not out of pocket. The three steps include: order form creation, approval, and submission. The process was found to add delays to ordering and not all teams ordered parts together. This creates budgeting issues for Mechanical vs Electrical teams.
3. PCB Design: Because no one on our EE team has PCB experience, this was a challenge. It was a very difficult task at first but it was a very valid one knowing the academic requirement was met.
4. Late Start: This project had a slow start. Because of the interdisciplinary process, there were many delays. We didn't have clear specifications from the client till six weeks into the semester.